



### Features

- 12.1" TFT 1024x768 XGA 4:3 LCD
- Resistive 5-wire or Projected Capacitive Touch
- 1x VGA, 1x DVI-D, 1x HDMI, 1x DisplayPort, 1x USB 2.0, 1x COM, 1x Audio
- 9 to 48 VDC wide range power input
- -10 °C to 60 °C extended operating temperature
- Aluminum die-casting front panel
- IP65 compliant front panel
- Two 5W internal speakers
- Multi-language OSD
- VESA mount option
- High Brightness Display and Optical Bonding (Optional)

### Specifications

Display	
IP Rating	IP65
LCD Size	12.1" (4:3)
Max. Resolution	1024 x 768 (XGA)
Brightness (cd/m <sup>2</sup> )	600 / 1000 (optional)
Contrast Ratio	1000:1
LCD Color	16.2M
Pixel Pitch (mm)	0.24(H) x 0.24(V)
Viewing Angle	178/178
Backlight MTBF	50000 hrs (LED Backlight)
Touch Type	Resistive 5-Wire Projective Capacitive
I/O	
Audio	1x Audio Input
COM	1x COM (For Resistive Touch)
USB	1x USB 2.0 (For Resistive Touch or P-CAP Touch)
DP	1x DP
DVI	1x DVI-D
HDMI	1x HDMI
VGA	1x VGA
Optical Bonding	Optional, contact us for more information
OSD	LCD On/Off, Auto, Menu Up And Down Multi-Language
Speaker	AMP 5W + 5W
Power	
Power Adapter	Optional AC/DC 12V/5A, 60W
Power Management	Power Ignition Management
Power Mode	AT, ATX
Power Supply Voltage	9~48 VDC
Power Connector	3-Pin Terminal Block
Power Protection	OVP (Over Voltage Protection) OCP (Over Current Protection) Reverse Protection
Environment	
Operating Temperature	-10 °C ~ 60 °C (14 °F ~ 140 °F)
Storage Temperature	-20 °C to 70 °C (-4 °F to 158 °F)
Relative Humidity	10% ~ 80% (non-condensing)
IP Level	IP 65 Compliant Front Panel
Certification	UL 62368 Ed. 3, CE, FCC Class A
Vibration	1.5 Grms, 5 - 500 Hz, 0.5 hr/axis
Shock	20G, half sine, 11ms
Physical	
Dimensions	319 x 257 x 61.7 mm (12.6" x 10.1" x 2.4")

Weights	VIO-212R-MX100: 4.20 kg (9.3 lb)
	VIO-212C-MX100: 4.14 kg (9.1 lb)
Mounting Options	VESA Mounting Holes 75 x 75mm, 100 x 100mm

### Available Models

- VIO-212C-13  
12.1" XGA Capacitive Touch Thin Frame Display Module with 2x 2W Speaker
- VIO-212HC-13  
VIO-212HC,12.1",XGA,CAPACITIVE,HB,2X2W SPK,V13
- VIO-212HC-13-OB  
VIO-212HC,12.1",XGA,CAPACITIVE,HB,OB,2X2W SPK,V13
- VIO-212HR-13  
VIO-212HR,12.1",XGA,RESISTIVE,HB,2X2W SPK,V13
- VIO-212HR-13-OB  
VIO-212HR,12.1",XGA,RESISTIVE,HB,OB,2X2W SPK,V13
- VIO-212R-13  
12.1" XGA Resistive Touch Thin Frame Display Module with 2x 2W Speaker
- MX100H-P  
Touch Screen Module ,1x HDMI,1x VGA,1x DP,1x USB2.0, 60W

### Optional Accessories

- 1-E09A06008  
Adapter AC/DC 12V 5A 60W with 3pin Terminal Block Plug 5.0mm Pitch
- 999930  
Power Cord, 3-pin US Type, 180cm
- 1-TPCD00002  
Power Cord, European Type, 180cm
- 1-TPCD00001  
Power Cord, 3-pin UK Type, 180cm

### Packing List

- 1x VIO-212-MX100H
- 1x Panel Mount Kit
- 1x USB Cable
- 1x VGA Cable
- 1x Screw Pack

### Exports And Tariff Codes

ECCN	EAR99
HTS	8528.59.1500
ScheduleB	85.28

\* All specifications and photos are subject to change without notice.

External I/O Mechanical Layout

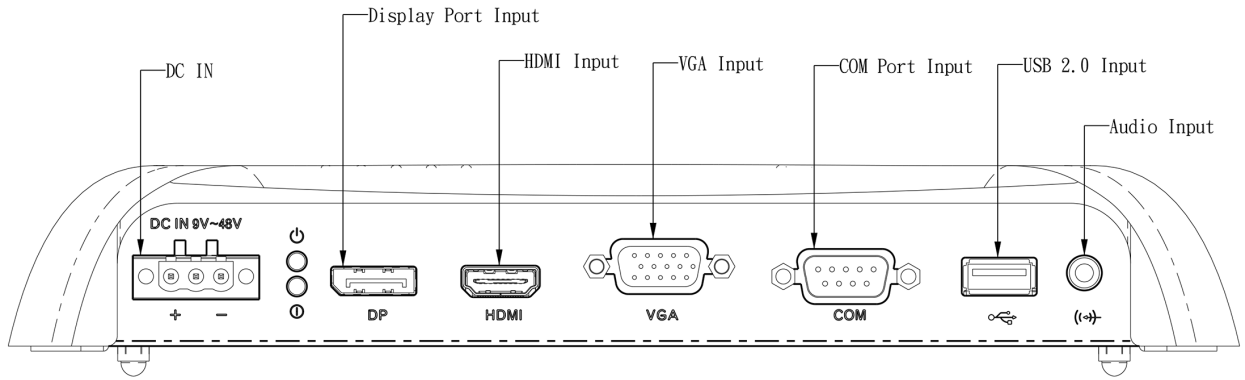

Dimension

Unit: mm

