

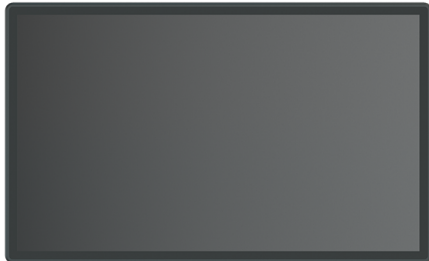

# VIO-W221-MX100H

21.5" 16:9 IP65 Industrial Touchscreen Monitor



## Features

- 21.5" TFT 1920×1080 FHD 16:9 LCD
- Resistive 5-wire or Projected Capacitive Touch
- 1x VGA, 1x DVI-D, 1x HDMI, 1x DisplayPort, 1x USB 2.0, 1x COM, 1x Audio
- 9 to 48 VDC wide range power input
- -10 °C to 60 °C extended operating temperature
- Aluminum die-casting front panel
- IP65 compliant front panel
- Two 10W internal speakers
- Multi-language OSD
- VESA mount option
- High Brightness Display and Optical Bonding (Optional)

## Specifications

Display Panel	
IP Rating	IP65
LCD Size	21.5" (16:9)
Max. Resolution	1920 x 1080 (FHD)
Brightness (cd/m <sup>2</sup> )	300 / 1000 (optional)
Contrast Ratio	5000:1
LCD Color	16.7M
Pixel Pitch (mm)	0.248(H) x 0.248(V)
Viewing Angle	178/178
Backlight MTBF	50000 hrs (LED Backlight)
Touch	
Touch Type	VIO-W221R-13, VIO-W221HR-13, VIO-W221HR-13-OB, VIO-W221C-13, VIO-W221HC-13, VIO-W221HC-13-OB
I/O	
Audio	1x Audio Input
COM	1x COM (For Resistive Touch)
USB	1x USB 2.0 (For Resistive Touch or P-CAP Touch)
DP	1x DP
DVI-D	1x DVI-D
HDMI	1x HDMI
VGA	1x VGA
Optical Bonding	Optional, contact us for more information
OSD	LCD On/Off, Auto, Menu Up And Down Multi-Language
Speaker	AMP 10W + 10W
Power	
Power Adapter	Optional AC/DC 12V/5A, 60W
Power Management	Power Ignition Management
Power Mode	AT, ATX
Power Supply Voltage	9~48 VDC
Power Connector	3-Pin Terminal Block
Power Protection	OVP (Over Voltage Protection) OCP (Over Current Protection) Reverse Protection
Environment	
Operating Temperature	-10 °C ~ 60 °C (14 °F ~ 140 °F)
Storage Temperature	-20 °C to 70 °C (-4 °F to 158 °F)
Relative Humidity	10% ~ 80% (non-condensing)

IP Level	IP 65 Compliant Front Panel
Certification	CE, FCC Class A
Physical	
Dimensions	528.5 x 324 x 71 mm (20.8" x 12.8" x 2.8")
Weights	VIO-W221R-MX100: 8.09 kg (17.8 lb) VIO-W221C-MX100: 7.77 kg (17.1 lb)
Mounting Options	VESA Mounting Holes 75 x 75mm, 100 x 100mm

## Available Models

VIO-W221C-13 21.5" Thin Frame Display Module, 16:9, FHD, Capacitive, 2x 10W Speaker
VIO-W221HC-13 21.5" Thin Frame Display Module, 16:9, FHD, Capacitive, High Brightness, 2x 10w Speaker, V13
VIO-W221HC-13-OB 21.5" Thin Frame Display Module, 16:9, FHD, Capacitive, High Brightness, Optical Bonding, 2x 10w Speaker, V13
VIO-W221HR-13 21.5" Thin Frame Display Module, 16:9, FHD, Resistive, High Brightness, 2x 10w Speaker, V13
VIO-W221HR-13-OB 21.5" Thin Frame Display Module, 16:9, FHD, Resistive, High Brightness, Optical Bonding, 2x 10w Speaker, V13
VIO-W221R-13 21.5" Thin Frame Display Module, 16:9, FHD, Resistive, 2x 10W Speaker MX100H-P Touch Screen Module ,1x HDMI,1x VGA,1x DP,1x USB2.0, 60W

## Packing List

- 1x VIO-W221-MX100H
- 1x Panel Mount Kit
- 1x USB Cable
- 1x VGA Cable
- 1x Screw Pack

## Exports And Tariff Codes

ECCN	EAR99
HTS	8528.59.1500
ScheduleB	85.28

\* All specifications and photos are subject to change without notice.

External I/O Mechanical Layout

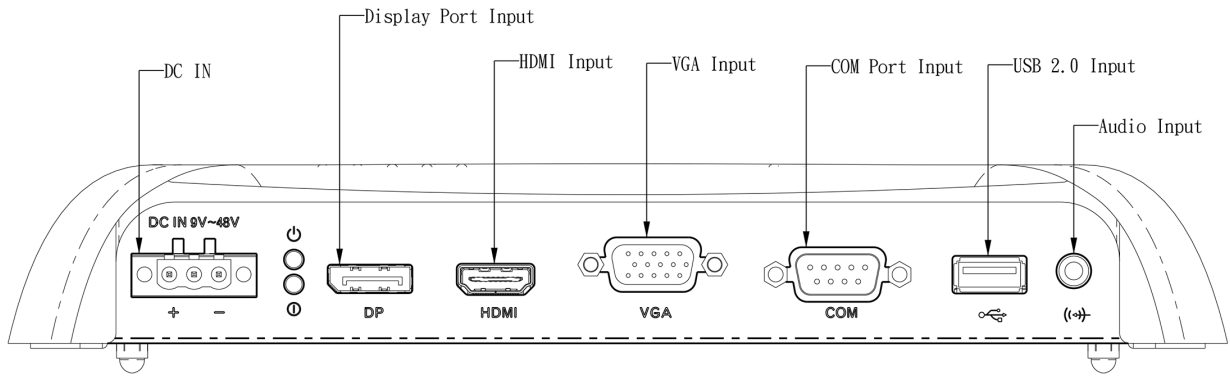

Dimension

Unit: mm

