



# VIO-215-PC100-EHL

15" XGA Resistive / Capacitive Touch Thin Frame Industrial Touchscreen Computer with Intel® Celeron® J6413

## Features

- 15" TFT XGA 4:3 LCD with resistive 5-wire / projected capacitive touch
- Intel® Celeron® Processor J6413
- 1x 260-pin DDR4 SODIMM. max up to 32GB
- 1x 2.5" SATA HDD bay, 1x mSATA, 2x SIM socket
- 1x Full-size Mini PCIe (USB 2.0, SATA)
- 2x LAN, 1x DP, 1x HDMI
- 6x RS-232/422/485 (w/ 2x internal)
- 2x USB 3.2 Gen 2, 2x USB 2.0
- 8x DI + 8x DO with isolation
- 9 to 36VDC wide range power input
- 0°C to 60°C extended operating temperature
- Designed with aluminum die-casting front frame
- IP65 compliant front panel / Fanless Industrial Display Computer
- Two 10W internal speakers built-in
- Multi-language OSD built-in
- 1x Universal I/O Bracket for 2x COM Expansion (PC100-EHL-1E Model)
- Edge AI Ready with Hailo-8™ (26 TOPS / 2.5W)
- UL Listed



## Specifications

Display	
IP Rating	IP65
LCD Size	15" (4:3)
Max. Resolution	1024 x 768 (XGA)
Brightness (cd/m <sup>2</sup> )	350 / 1000 (optional)
Contrast Ratio	1000:1
LCD Color	16.7M
Pixel Pitch (mm)	0.297(H) x 0.297(V)
Viewing Angle	170/160
Backlight MTBF	50000 hrs (LED Backlight)
Touch Type	Resistive 5-Wire Projective Capacitive
System	
Processor	Intel® Celeron® J6413 Processor Quad core (1.5M Cache, 1.8GHz up to 3.00 GHz) FC-BGA16F, Tray 10W
System Chipset	SoC Integrated
LAN Chipset	GbE1: Intel® I210 (Support Wake-on-LAN and PXE) 2.5 GbE2: Intel® I225 (Support Wake-on-LAN and PXE)
Audio Codec	Realtek ALC888S
System Memory	1x 260-Pin DDR4 2400/2667/3200MT/s SODIMM. Max. up to 32 GB
BIOS	AMI 128Mbit SPI BIOS
TPM	TPM 2.0
Watchdog	Software Programmable Supports 1~255 sec. System Reset
AI Accelerator	Supports 1x Hailo-8™ module
Storage	
M.2	1x M.2 (E Key, PCIe x1, USB 2.0, 2230) 1x M.2 (B Key, PCIe x2 + USB 3.2 Gen1, 2242/3042/3052)
mSATA	1x mSATA
SIM Socket	2x External SIM socket
SSD/HDD	1x Removable 2.5" SATA HDD Bay
Expansion	
Mini PCIe	1x Full-size Mini PCIe (USB 2.0, SATA)
PCIe	PC100-EHL-1E: 1x PCIe x4 (1-lane)
I/O	
Audio	1x Mic-in, 1x Line-out
CAN	2x CAN 2.0 A/B 2-pin Header (Internal)
COM	4x RS-232/422/485 2x RS-232/422/485 (internal)
DIO	8 in / 8 out (Isolated)
LAN	2x RJ45
Universal I/O Bracket	PC100-EHL-1E: 1x Universal I/O Bracket (By mini PCIe interface)
USB	2x USB 3.2 Gen 2 (10 Gbps) 2x USB 2.0
DP	1x DisplayPort 1.2 (4096 x 2160@60Hz)
HDMI	1x HDMI 2.0b (4096 x 2160@60Hz) (Optional)
Others	4x WiFi Antenna Holes 1x Power Switch, 1x AT/ATX Switch, 1x Remote Power On/Off 1x DB9 Cutting Hole
Optical Bonding	Optional, contact us for more information
Others Features	
Speaker	AMP 10W + 10W

OSD LCD On/Off, Auto, Menu, Up and Down Multi-language

Operating System	
Windows	Windows 10, Windows 11
Linux	Linux kernel 5.X
Power	
Power Adapter	Optional AC/DC 12V/5A, 60W
Power Management	Power Ignition Management (Optional Module)
Power Mode	AT, ATX
Power Supply Voltage	9~36 VDC
Power Connector	3-Pin Terminal Block
Power Protection	OVP (Over Voltage Protection) OCP (Over Current Protection) Reverse Protection
Environment	
Operating Temperature	0°C to 60°C
Storage Temperature	-20°C to 70°C
Relative Humidity	10%~80% (non-condensing)
IP Level	IP 65 Compliant Front Panel
Certification	UL 62368 Ed. 3, CE, FCC Class A
Vibration	With SSD: 1.5 Grms, 5 - 500 Hz, 0.5 hr/axis With HDD: 1 Grms, 5 - 500 Hz, 0.5 hr/axis
Shock	With SSD: 20G, half sine, 11ms
Physical	
Dimensions	VIO-215-PC100-EHL: 377 (W) x 301 (D) x 64.7 (H) mm VIO-215-PC100-EHL-1E: 377 (W) x 301 (D) x 87.7 (H) mm
Weights	VIO-215-PC100-EHL, Resistive Touch: 5.16 kg VIO-215-PC100-EHL, Capacitive Touch: 5.12 kg VIO-215-PC100-EHL-1E, Resistive Touch: 5.32 kg VIO-215-PC100-EHL-1E, Capacitive Touch: 5.24 kg
Mounting Options	VESA Mounting Holes 75 x 75mm, 100 x 100mm

External I/O Mechanical Layout

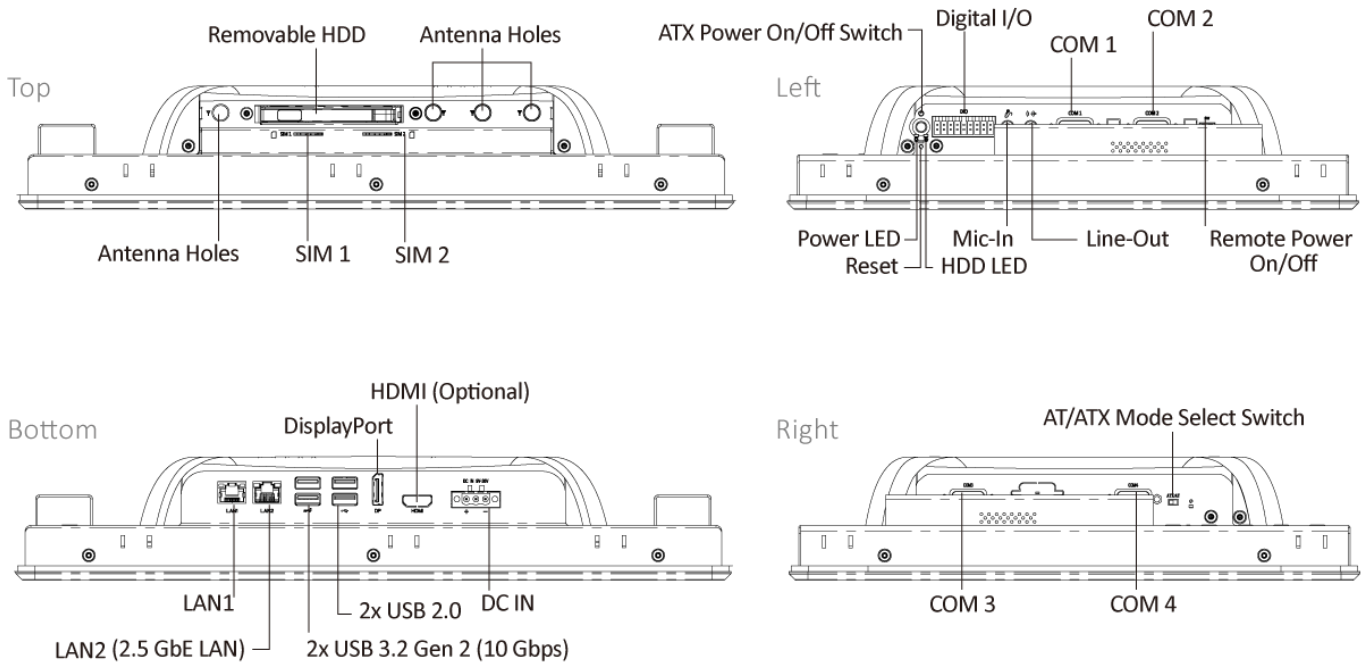

Dimension

Unit: mm

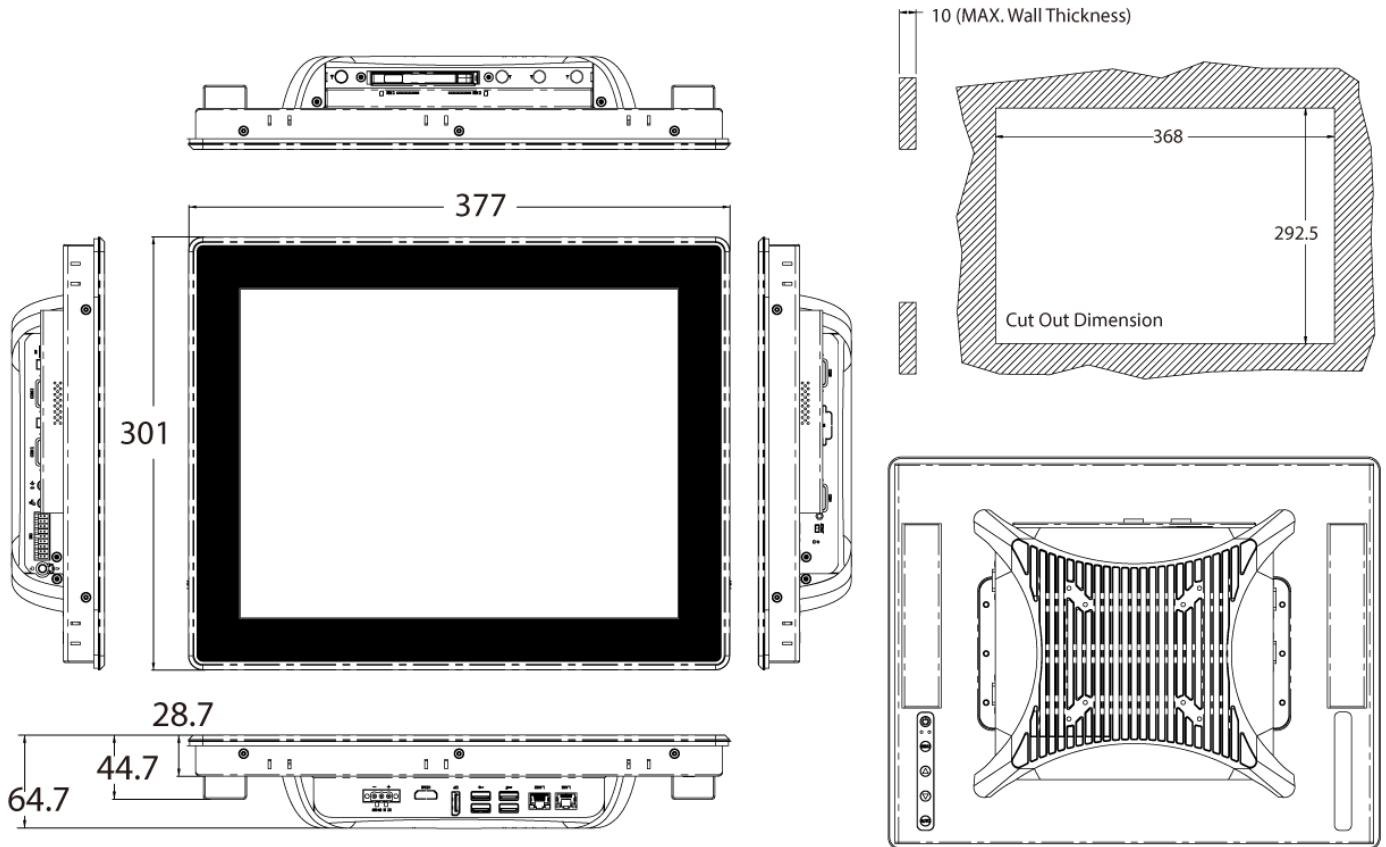

External I/O Mechanical Layout

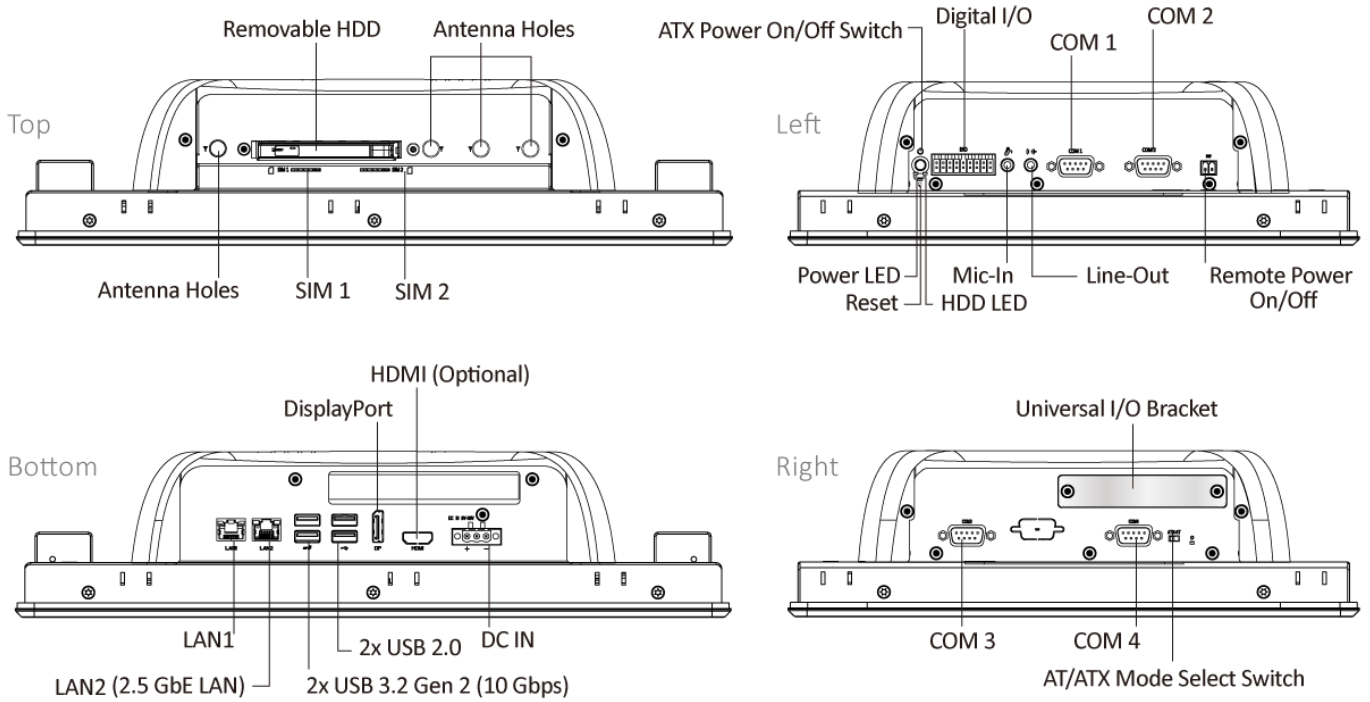

Dimension

Unit: mm

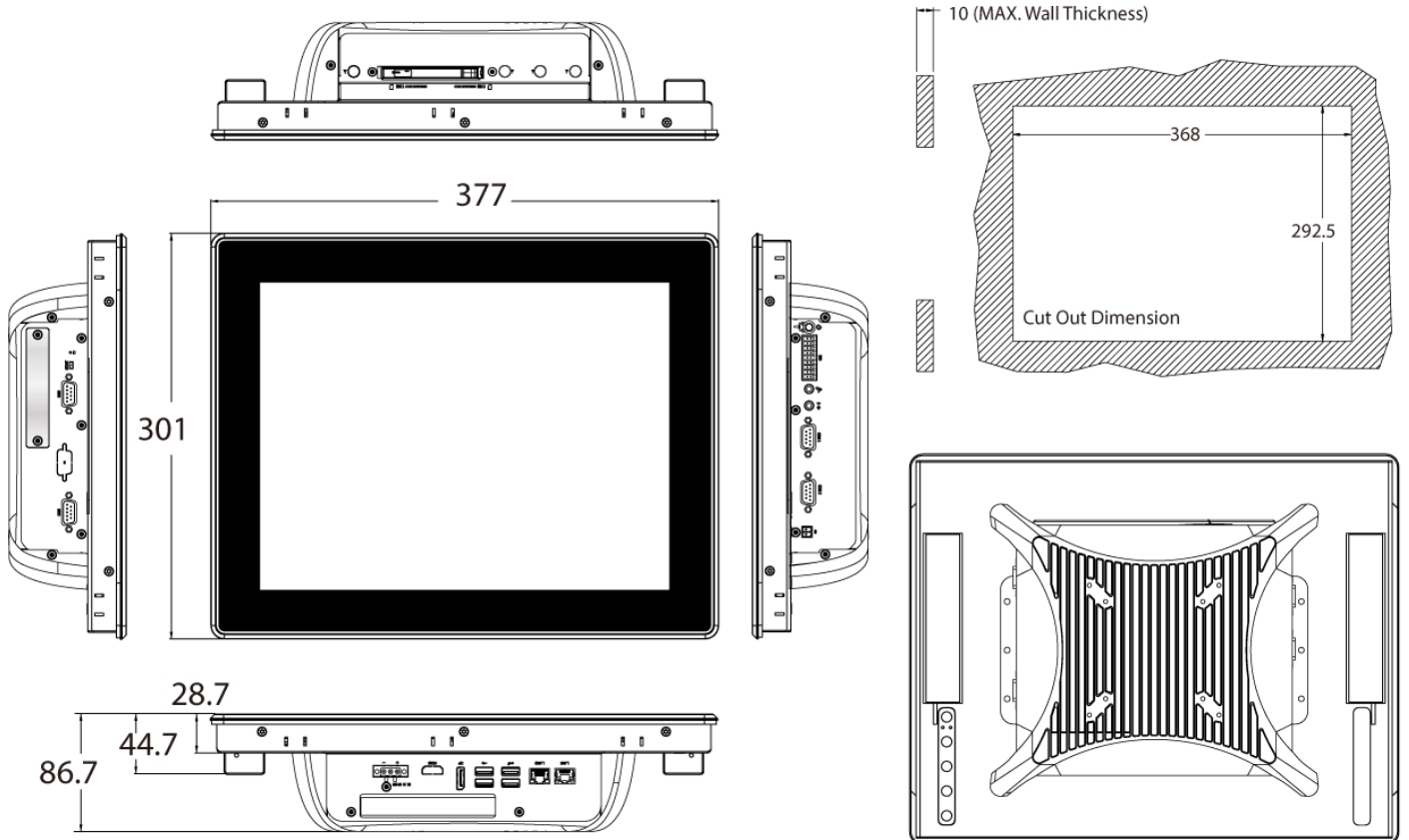

## Available Models

Model No.	Description
VIO-215C-15	15" XGA Capacitive Touch Thin Frame Display Module with 2x 10W Speaker
VIO-215HC-15	VIO-215HC,15",XGA,CAPACITIVE,HB,2X10W SPK,V15
VIO-215HC-15-OB	VIO-215HC,15",XGA,CAPACITIVE,HB,OB,2X10W SPK,V15
VIO-215HR-14	VIO-215HR,15",XGA,RESISTIVE,HB,2X10W SPK,V14
VIO-215HR-14-OB	VIO-215HR,15",XGA,RESISTIVE,HB,OB,2X10W SPK,V14
VIO-215R-14	15" XGA Resistive Touch Thin Frame Display Module with 2x 10W Speaker
PC100-EHL-J6413-P	PC100-EHL-J6413,60W,POWER CORD
PC100-EHL-J6413-10-P	PC100-EHL-J6413,PCIEX4(X1),60W,POWER CORD

## Optional Accessories

Model No.	Description
1-E09A06008	Adapter AC/DC 12V 5A 60W with 3pin Terminal Block Plug 5.0mm Pitch
999930	Power Cord, 3-pin US Type, 180cm
1-TPCD00002	Power Cord, European Type, 180cm
1-TPCD00001	Power Cord, 3-pin UK Type, 180cm
PC100-2COM-KIT	MOD,2XDB9(COM 5,6) KIT,PC100-EHL
PC100-EHL-5G-KIT	MOD,PC100-EHL,5G,THALES,KIT
PC100-EHL-10-5G-KIT	MOD,PC100-EHL-10,5G,THALES,KIT
PC100-EHL-TPU-KIT	MOD,PC100-EHL,TPU,HAILO-8,KIT
PC100-EHL-10-TPU-KIT	MOD,PC100-EHL-10,TPU,HAILO-8,KIT
3-PC1200AIKIT-S0	MOD,HAILO/NVME THERMAL KIT,PC100-EHL
3-PC1210AIKIT-S0	MOD,HAILO/NVME THERMAL KIT,PC100-EHL-10
1-TCAN00001	CBL,CANBUS,DB9,DUAL CHANNEL

## Packing List

- 1x VIO-200-PC100-EHL Series
- 10x Panel Mount Kit
- 1x Screw Pack

## Exports And Tariff Codes

ECCN	5A992.c
HTS	8471.50.0150
ScheduleB	84.71