

USER'S MANUAL

CT-DAS02 Series 3.5" SBC Industrial Motherboard

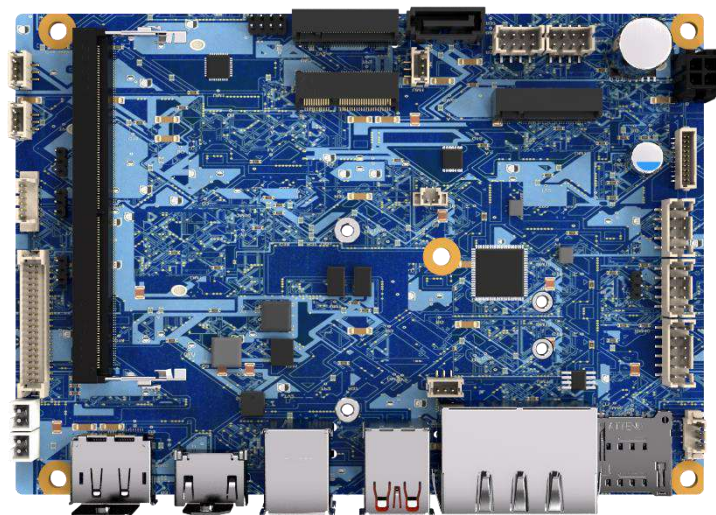

Table of Contents

Prefaces	04
Revision	04
Disclaimer	04
Copyright Notice	04
Trademarks Acknowledgment	04
Environmental Protection Announcement	04
Regulatory Notices	05
Battery Information	06
Safety Information	08
Technical Support and Assistance	09
Chapter 1 Product Introductions	10
1.1 Product Description	11
1.2 Specifications	12
1.3 Available Models	14
1.4 Optional Accessories	14
Chapter 2 Switches and Connectors	15
2.1 Switch and Connector Locations	16
Top View	16
Bottom view	16
2.2 Connector / Switch Definition	17
2.3 Definition of Connectors	18
2.3.1 DC Power Input	18
2.3.2 I/O Front Panel	18
2.3.3 LAN1/LAN2	19
2.3.4 JUSB1/JUSB2	20
2.3.5 CAN	21
2.3.6 BAT1	22
2.3.7 Jumper	23
2.3.8 eDP/LVDS	24
2.3.9 LED Backlight	25
2.3.10 COM	26
2.3.11 OOB	27
2.3.12 SIM	28
2.3.13 SATA	29
2.3.14 SATA power	29
2.3.15 JAUDIO1	30
2.3.16 Left+Right Amplifier	30

Chapter 3	BIOS Setup	31
3.1	BIOS Introduction	32
3.2	Main Setup	33
3.3	Advanced Setup	34
	3.2.1 CPU Configuration	35
	3.3.2 PCH-FW Configuration	37
	3.3.3 Intel® Time Coordinated Computing	38
	3.3.4 Trusted Computing	40
	3.3.5 ACPI Settings	41
	3.3.6 Super IO Configuration	42
	3.3.7 Hardware Monitor	47
	3.3.8 S5 RTC Wake Settings	48
	3.3.9 Serial Port Console Redirection	49
	3.3.10 USB Configuration	50
	3.3.11 Network Stack Configuration	51
	3.3.12 NVMeConfiguration	52
3.4	Chipset	53
	3.4.1 System Agent (SA) Configuration	54
	3.4.2 PCH-IO Configuration	57
3.5	Security	60
3.6	Boot	65
3.7	Save & Exit	66
Appendix	67
	WDT Sample Code.....	68
	GPIO Sample Code.....	69

Prefaces

Revision

Revision	Description	Date
1.0	Manual Released	2026/5/15

Disclaimer

All specifications and information in this User's Manual are believed to be accurate and up to date. Premio Inc. does not guarantee that the contents herein are complete, true, accurate or non-misleading. The information in this document is subject to change without notice and does not represent a commitment on the part of Premio Inc.

Premio Inc. disclaims all warranties, express or implied, including, without limitation, those of merchantability, fitness for a particular purpose with respect to contents of this User's Manual. Users must take full responsibility for the application of the product.

Copyright Notice

All rights reserved. No part of this manual may be reproduced or transmitted in any form or by any means, electronic or mechanical, including photocopying, recording, or information storage and retrieval systems, without the prior written permission of Premio Inc. Copyright © Premio Inc.

Trademarks Acknowledgment

Intel®, Celeron® and ATOM® are trademarks of Intel Corporation.

Windows® is registered trademark of Microsoft Corporation.

AMI is trademark of American Megatrend Inc.

IBM, XT, AT, PS/2 and Personal System/2 are trademarks of International Business Machines Corporation

All other products and trademarks mentioned in this manual are trademarks of their respective owners.

Environmental Protection Announcement

Do not dispose this electronic device into the trash while discarding. Please recycle to minimize pollution and ensure environment protection.

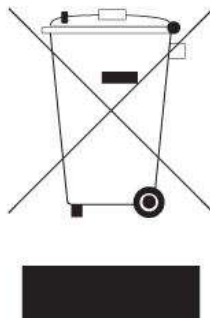

Regulatory Notices

FCC-A Radio Frequency Interference Statement

This equipment has been tested and found to comply with the limits for a Class A digital device, pursuant to part 15 of the FCC rules. These limits are designed to provide reasonable protection against harmful interference in a residential installation. This equipment generates, uses and radiates radio frequency energy, and, if not installed and used in accordance with the instructions, may cause harmful interference to radio communications. However, there is no guarantee that interference will not occur in a particular installation. If this equipment does cause harmful interference to radio or television reception, which can be determined by turning the equipment off and on, the user is encouraged to try to correct the interference by one or more of the following measures:

- Reorient or relocate the receiving antenna.
- Increase the separation between the equipment and receiver.
- Connect the equipment into an outlet on a circuit different from that to which the receiver is connected.

NOTE

- The changes or modifications not expressly approved by the party responsible for compliance could void the user's authority to operate the equipment.
- Shield interface cables and AC power cord, if any, must be used in order to comply with the emission limits.

FCC Conditions

This device complies with part 15 of the FCC Rules. Operation is subject to the following two conditions:

- This device may not cause harmful interference.
- This device must accept any interference received, including interference that may cause undesired operation.

CE Conformity

Hereby, Premio Inc. declares that this device is in compliance with the essential safety requirements and other relevant provisions set out in the European Directive.



WEEE Statement

Under the European Union ("EU") Directive on Waste Electrical and Electronic Equipment, Directive 2012/19/EU, products of "electrical and electronic equipment" cannot be discarded as municipal waste anymore and manufacturers of covered electronic equipment will be obligated to take back such products at the end of their useful life.

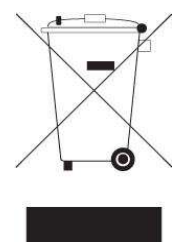

Battery Information

Please take special precautions if this product comes with a battery.

- Danger of explosion if battery is incorrectly replaced. Replace only with the same or equivalent type recommended by the manufacturer.
- Avoid disposal of a battery into fire or a hot oven, or mechanically crushing or cutting of a battery, which can result in an explosion.
- Avoid leaving a battery in an extremely high temperature or extremely low air pressure environment that can result in an explosion or the leakage of flammable liquid or gas.
- Do not ingest battery. If the coin/button cell battery is swallowed, it can cause severe internal burns and can lead to death. Keep new and used batteries away from children.

European Union:



Batteries, battery packs, and accumulators should not be disposed of as unsorted household waste. Please use the public collection system to return, recycle, or treat them in compliance with the local regulations.

BSMI:



For better environmental protection, waste batteries should be collected separately for recycling or special disposal.

California, USA:



The button cell battery may contain perchlorate material and requires special handling when recycled or disposed of in California.

For further information please visit:

<http://www.dtsc.ca.gov/hazardouswaste/perchlorate/>

Chemical Substances Information

In compliance with chemical substances regulations, such as the EU REACH Regulation (Regulation EC No. 1907/2006 of the European Parliament and the Council), Premio provides the information of chemical substances in products at:

www.premioinc.com

Environmental Policy

- The product has been designed to enable proper reuse of parts and recycling and should not be thrown away at its end of life.
- Users should contact the local authorized point of collection for recycling and disposing of their end-of-life products.
- Visit the Premio website and locate a nearby distributor for further recycling information.
- Users may also reach us at Premio for information regarding proper Disposal, Take-back, Recycling, and Disassembly of Premio products.



Green Product Features

- Reduced energy consumption during use and stand-by
- Limited use of substances harmful to the environment and health
- Easily dismantled and recycled
- Reduced use of natural resources by encouraging recycling
- Extended product lifetime through easy upgrades
- Reduced solid waste production through take-back policy

Copyright and Trademarks Notice

Copyright Premio Inc. All rights reserved. The Premio logo used is a registered trademark of Premio Inc. All other marks and names mentioned may be trademarks of their respective owners. No warranty as to accuracy or completeness is expressed or implied. Premio reserves the right to make changes to this document without prior notice.

Technical Support

If a problem arises with your product and no solution can be obtained from the user's manual, please contact your place of purchase or local distributor. Alternatively, please visit

www.premioinc.com

Safety Information

Before installing and using the equipment, please read the following precautions:

- The components included in this package are prone to damage from electrostatic discharge (ESD). Please adhere to the following instructions to ensure successful computer assembly.
- Ensure that all components are securely connected. Loose connections may cause the computer to not recognize a component or fail to start.
- Hold the motherboard by the edges to avoid touching sensitive components.
- It is recommended to wear an electrostatic discharge (ESD) wrist strap when handling the motherboard to prevent electrostatic damage. If an ESD wrist strap is not available, discharge yourself of static electricity by touching another metal object before handling the motherboard.
- Store the motherboard in an electrostatic shielding container or on an anti-static pad whenever the motherboard is not installed.
- Before turning on the computer, ensure that there are no loose screws or metal components on the motherboard or anywhere within the computer case.
- Do not boot the computer before installation is completed. This could cause permanent damage to the components as well as injury to the user.
- If you need help during any installation step, please consult a certified computer technician.
- Always turn off the power supply and unplug the power cord from the power outlet before installing or removing any computer component.
- Keep this user guide for future reference.
- Keep this motherboard away from humidity.
- Make sure that your electrical outlet provides the same voltage as is indicated on the PSU, before connecting the PSU to the electrical outlet.
- Place the power cord such a way that people can not step on it. Do not place anything over the power cord.
- All cautions and warnings on the motherboard should be noted.
- If any of the following situations arises, get the motherboard checked by service personnel:
 - Liquid has penetrated into the computer.
 - The motherboard has been exposed to moisture.
 - The motherboard does not work well or you can not get it work according to user guide.
 - The motherboard has been dropped and damaged.
 - The motherboard has obvious sign of breakage.
- Do not leave this motherboard in an environment above 60°C (140°F), it may damage the motherboard

Technical Support and Assistance

1. Visit the Premio Inc website at www.premioinc.com where you can find the latest information about the product.
2. Contact your distributor, our technical support team or sales representative for technical support if you need additional assistance. Please have following information ready before you call:
 - Model name and serial number
 - Description of your peripheral attachments
 - Description of your software (operating system, version, application software, etc.)
 - A complete description of the problem
 - The exact wording of any error messages

Conventions Used in this Manual



WARNING

This indication alerts operators to an operation that, if not strictly observed, may result in severe injury.



CAUTION

This indication alerts operators to an operation that, if not strictly observed, may result in safety hazards to personnel or damage to equipment.



NOTE

This indication provides additional information to complete a task easily.

Chapter 1

Product Introductions

1.1 Product Description

3.5" SBC Industrial Motherboard



- Supports Intel® N150/N97 Processors
- 1x 262-pin DDR5 4800 MT/s SO-DIMM. Max. up to 32GB (Non-ECC)
- 2x Intel® i226V 2.5 GbE
- Triple independent displays supported: DP, HDMI, LVDS or eDP
- 1x M.2 M key 2280 NVMe, 1x M.2 E key 2230
- 1x M.2 B key 2242 NVMe/5G, 1x Dual Nano SIM Slot
- 3x USB 3.2 Gen 1 Type A, 1x USB 3.2 Gen 1 Type C, 3x USB 2.0 (Internal)
- 1x RS-232/422/485 (Internal); 1x RS-232 (Internal), 1x DIO
- 1x SATA 3.0 6Gb/s (Support AHCI), shared with M.2 B-Key
- Watchdog timer 1~255 sec. System reset
- TPM 2.0 Supported
- Wide Voltage DC IN 9~36V
- Wide Temperature -10°C to 60°C

1.2 Specifications

System	
Processor	<ul style="list-style-type: none"> • Intel® Processor N97, 6MB Cache, up to 3.60 GHz, 4-Core Processor • Intel® Processor N150, 6MB Cache, up to 3.60 GHz, 4-Core Processor
System Chipset	SoC
LAN Chipset	GbE1: Intel i226V 2.5GbE LAN GbE2: Intel i226V 2.5GbE LAN
Audio Codec	Realtek® ALC888S with Amp 5W
Memory	1x 262-Pin DDR5 4800 MT/s SO-DIMM. Max. up to 32GB (Non-ECC)
Graphics	Intel® UHD Graphics
BIOS	AMI uEFI 256MB SPI flash
TPM	TPM 2.0

Display	
Display Port	1x DP 1.4 up to 4096x2304 @60Hz
HDMI	1x HDMI 2.0b up to 4096 x 2160@60Hz
Multiple Display	1x eDP / 1x LVDS (Combin connector)

Storage	
M.2	1x M.2 M Key (2280, PCIe x2) support for NVMe

Expansion	
M.2	<ul style="list-style-type: none"> • 1x M.2 B Key (2242/3042/3052, PCIe x1, USB 3.0) support for NVMe, 4G/5G Module • 1x M.2 E Key (2230, PCIe x1, USB 2.0) support for Wifi/Bluetooth

I/O	
Display Port	1x DisplayPort
HDMI	1x HDMI
LAN	2x 2.5GbE RJ45
SIM	1x Dual Nano SIM Socket
USB	3x USB 3.2 Gen 1 Type A 1x USB 3.2 Gen 1 Type C 2x USB 2.0 Pin header 3port

Internal I/O	
COM	2x RS-232/422/485 Internal
DIO	4 in / 4 out (None Isolated)
OOB	Internal header (2x UART)
Others	1x Front Panel con 1x Audio con (1x Audio out, 1x Audio Amp out)

Operating System	
Windows	Windows 10/11
Linux	Linux Ubuntu 22.04 / 24.04 LTS

Power	
Power Adapter	Optional AC/DC 12V/5A, 60W
Power Mode	AT, ATX
Power Supply Voltage	DC IN 9~36V
Power Connector	Micro fit pitch 3.0 2x2 pin
Power Protection	OVP (Over Voltage Protection) OCP (Over Current Protection) DC Surge Protection

Mechanical Environment	
Form Factor	3.5" Embedded SBC
Operating Temperature	-10°C to 60°C
Storage Temperature	-20°C to 70°C
Relative Humidity	10% to 95% (non-condensing)
Certification	CE, FCC Class B, UKCA, UL62368

Physical	
Dimensions	146 x 102mm
Weights	0.58kg

1.3 Available Models

Ordering Information	DESCRIPTION
CT-DAS02-N150-KIT-P	Industrial 3.5" SBC Motherboard with Intel® N150 Processors 3.5" SBC, 2x 2.5GbE LAN with Cable & Heatsink Kit
CT-DAS02-N97-KIT-P	Industrial 3.5" SBC Motherboard with Intel® N97 Processors 3.5" SBC, 2x 2.5GbE LAN with Cable & Heatsink Kit

1.4 Optional Accessories

1-TBTN00015	Button Cable with LED 150mm
1-TCOM00056	Dual COM Cable 150mm
1-TUSB00070	USB 2.0 Y Cable 200mm
1-TUSB00118	USB 2.0 Single Port Cable
1-TDIO00008	DIO Cable 10pin 250mm
1-TADO00027	Audio Cable Line-in / Mic-in 100mm
1-TADO00019	Audio Amp Extended Cable
1-TSAT00027	SATA7+15P Cable
1-TPWR00123	4P Micro Fit To DC Plug 5.5 x 2.5 With Lock 150mm
1-EOCB08D01	Speaker_8ohm_2W_L=500mm
1-E09A06012	Adapter 60W/12V W/Lock 5.5/2.5mm Input 100/240VAC
1-TPCD00005	AC Power Cord US Type, L=1830mm
1-TPCD00003	AC Power Cord JAP Type, L=1830mm
1-TPCD00002	AC Power Cord European Type, L=1713mm

Chapter 2

Switches and Connectors

2.1 Switch and Connector Locations

Top View

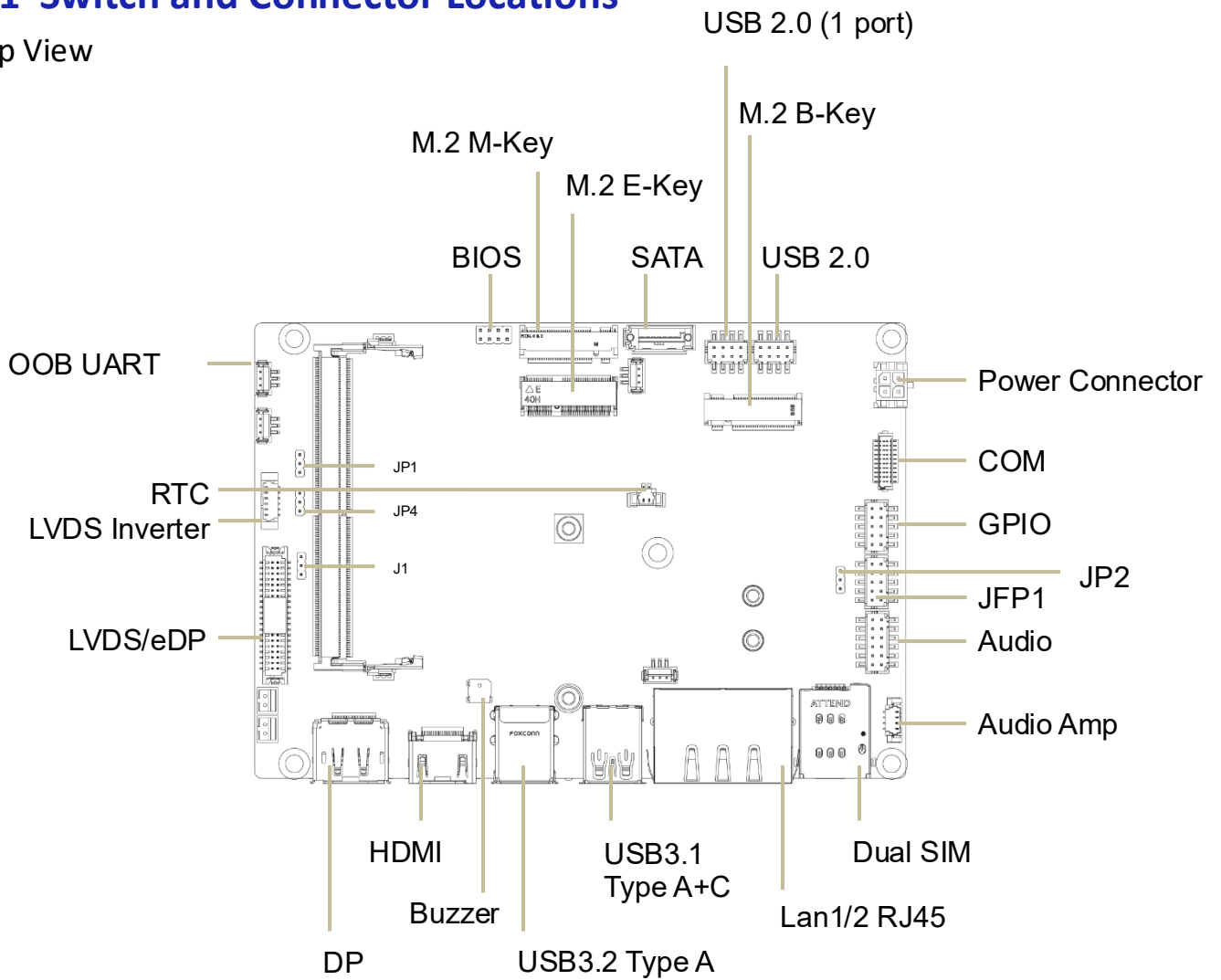

Bottom view

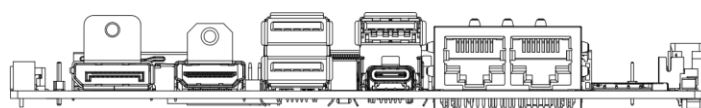
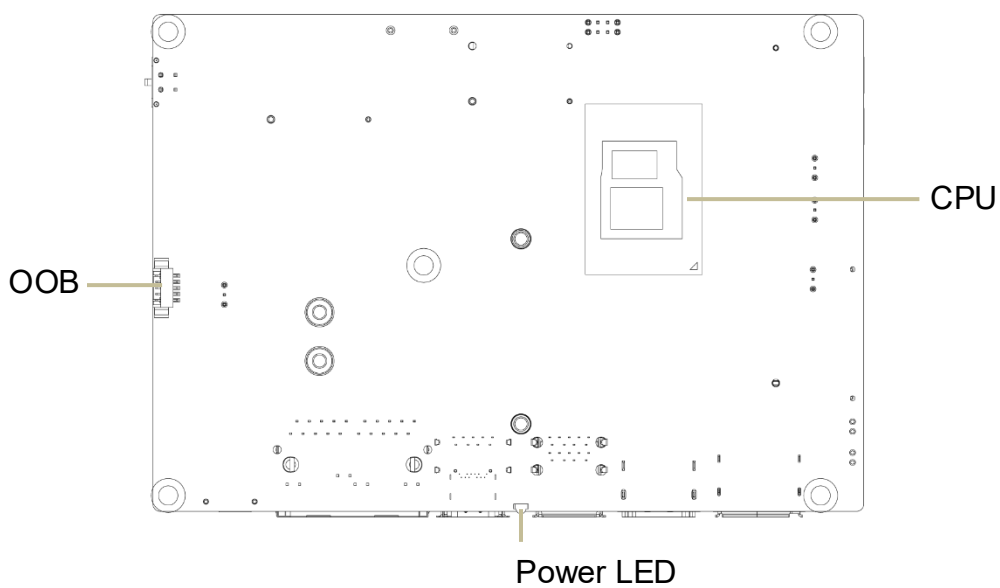

2.2 Connector / Switch Definition

Connector Location	Definition
M.2 B-Key	PCIe x1+USB3.0+USB2, Support 5G/4G
M.2 E-Key	PCIe+USB2.0, Support WIFI+BLE
LVDS / eDP	LVDS max 1920*1200@60Hz eDP max 4096*2160@60Hz
DDR5 SO-DIMM slot	DDR5 4800 MT/s Non-ECC SO-DIMM
Power LED	LED SMD 2 Color
USB3.2 Type A	USB3.2 Gen1 Type A x3
USB3.2 Type C	USB3.2 Gen1 (5 Gbps) Type C
Lan1/2 RJ45	Intel I226V 2.5GT/s
HDMI	HDMI 2.0b (4096x2160@60HZ)
DP	DisplayPort 1.4, (4096 x2160@60Hz)
Dual SIM	Dual Nano SIM card
M.2 M-Key	PCIe x2 GEN3 Support NVME
FPC	Front Panel Connector
M.2 B-Key Screw	M.2 B-Key Screw x2
M.2 M-Key Screw	M.2 E-Key NUT
LVDS Inverter Connector	LVDS Inverter PWR
Power Connector	4 Pin Micro-Fit Power Connector
USB 2.0	USB2.0
GPIO	4xGPI+4xGPO, non-isolated 5V
Audio	Wafer, Line-in+Line-out+Mic
Buzzer	Buzzer
RTC	CR2032 Battery
Audio Amp	Wafer L/R Amplifier 5W
COM Port	COM1 RS232/RS422/RS485 COM2 RS232
SATA	SATA Connector x1
SATA Power	Wafer SATA Power Connector
JP1	JP1 Clear CMOS
JP4	JP4 Inverter Power 5V/12V
J1	J1 LCD Power 3.3V/5V
BIOS	Pin Header eSPI
OOB	Wafer OOB
RT1	NTC Thermistors

2.3 Definition of Connectors

2.3.1 DC 9V~36V Power Input: Micro-Fit, 2*2P, 3.00mm

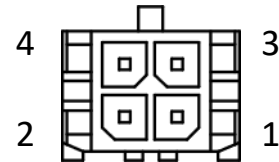
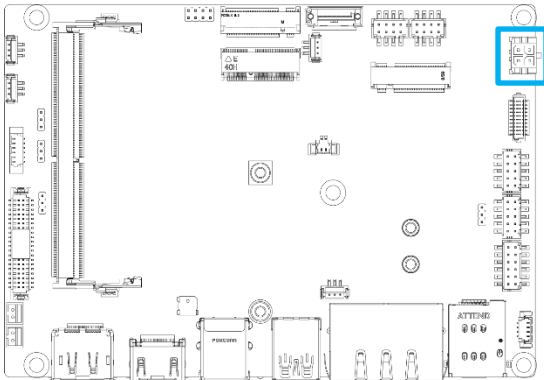

DC Power Input

Pin	Definition	Pin	Definition
1	GND	2	GND
3	DC_IN	4	DC_IN

2.3.2 I/O Front Panel: Wafer, 5x2P,2.00mm

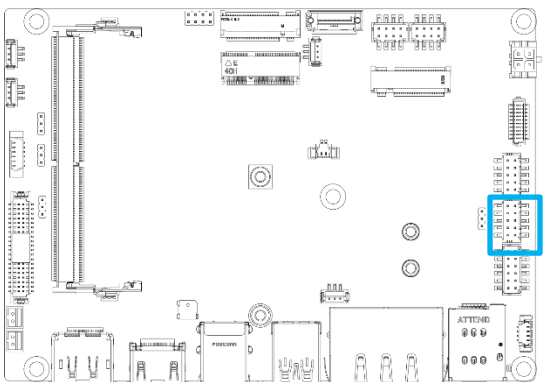

JFP1

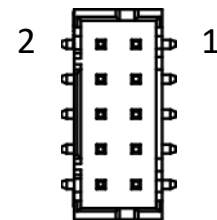

Pin	Definition	Pin	Definition
1	N/C	2	N/C
3	RESET_BUT	4	Power On-
5	GND	6	Power On+
7	HDD LED-	8	SUS LED
9	HDD LED	10	Power LED

2.3.3 LAN 2.5GbE (Gigabit Ethernet)

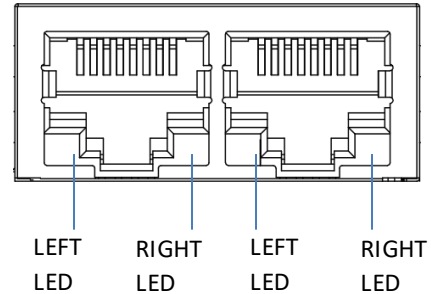
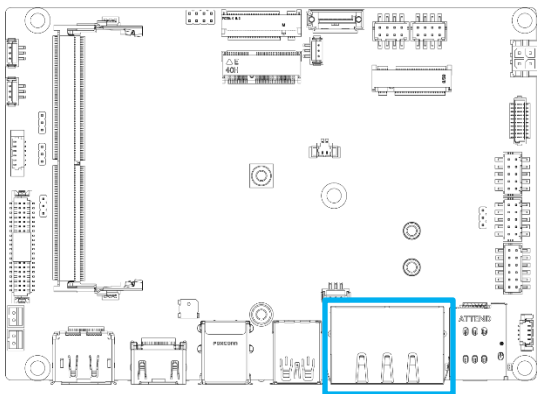

LAN1: RJ45,8P

Pin	Definition	Pin	Definition
1	LAN1_MDI0_P	5	LAN1_MDI2_P
2	LAN1_MDI0_N	6	LAN1_MDI2_N
3	LAN1_MDI1_P	7	LAN1_MDI3_P
4	LAN1_MDI1_N	8	LAN1_MDI3_N
Active LED	ACT: Twinkling Yellow	Speed LED	1000M: Turn Orange
	Only LINK: Light On		2.5G: Turn Green
	No LINK: Light Off		10M: Light Off

LAN2: RJ45,8P

Pin	Definition	Pin	Definition
11	LAN1_MDI0_P	15	LAN1_MDI2_P
12	LAN1_MDI0_N	16	LAN1_MDI2_N
13	LAN1_MDI1_P	17	LAN1_MDI3_P
14	LAN1_MDI1_N	18	LAN1_MDI3_N
Active LED	ACT: Twinkling Yellow	Speed LED	1000M: Turn Orange
	Only LINK: Light On		2.5G: Turn Green
	No LINK: Light Off		10M: Light Off

2.3.4 JUSB1/JUSB2: USB2.0 Wafer, 4x2P, 2.00mm

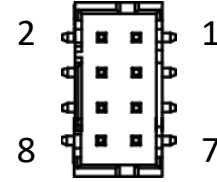
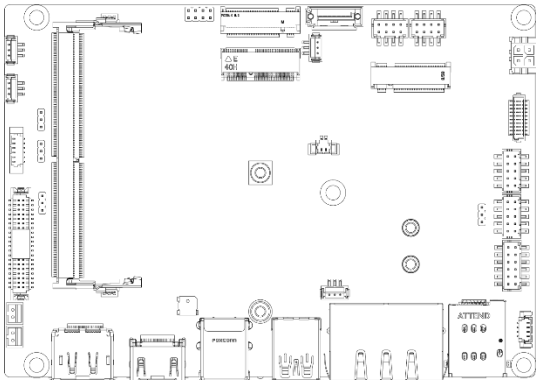

JUSB1

Pin	Definition	Pin	Definition
1	GND	2	N/C
3	USB2+	4	N/C
5	USB2-	6	N/C
7	+5V	8	N/C

JUSB2

Pin	Definition	Pin	Definition
1	GND	2	+5V
3	USB2+	4	USB2-
5	USB2-	6	USB2+
7	+5V	8	GND

2.3.6 BAT1: Battery socket: Wafer, 2*1P, 1.25mm

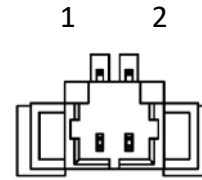
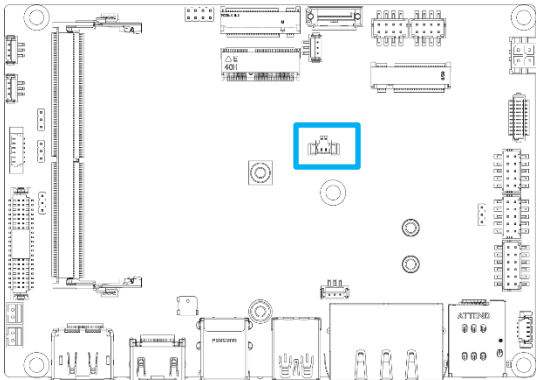

BAT1

Pin	Definition
1	Battery power
2	GND

2.3.7 Jumper

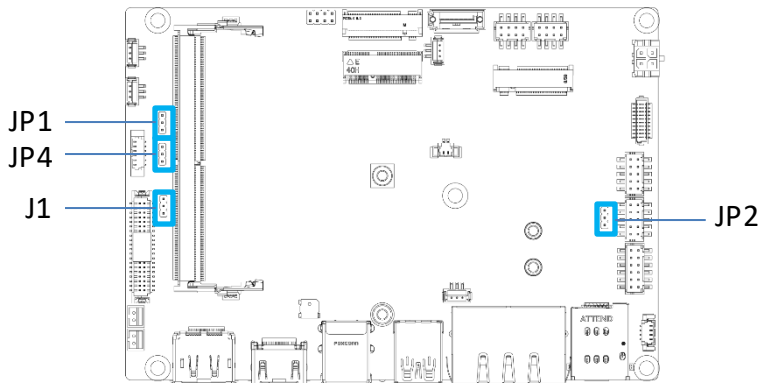

JP1:Clear CMOS, 1*3P, Pitch, 2.00mm

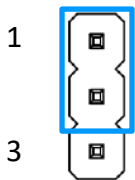

Pin	Definition
1-2	Default*
2-3	Clear CMOS

JP2:AT/ATX, 1*3P, Pitch, 2.00mm

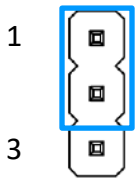

Pin	Definition
1-2	ATX Default*
2-3	AT

JP4: Inverter Power 5V/12V, 1*3P, Pitch, 2.00mm

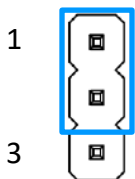

Pin	Definition
1-2	+5V Default
2-3	+12V

J1 LCD/eDP Power 3.3V/5V, 1*3P, Pitch, 2.00mm

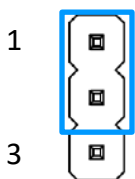

Pin	Definition
1-2	+3.3V Default
2-3	+5V

2.3.8 LVDS/eDP: DF13, 20*2P, 1.25mm

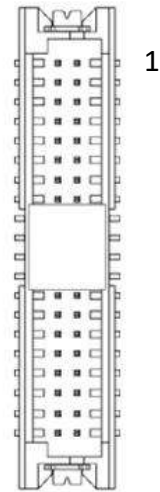
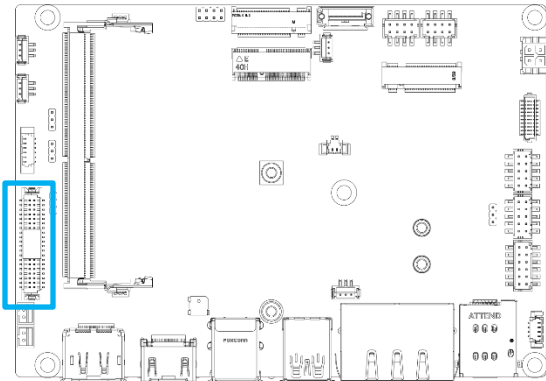

LVDS/eDP

Pin	Definition	Pin	Definition
1	12V	2	12V
3	LCD_VDD	4	12V
5	LCD_VDD	6	LCD_VDD
7	DDC_CLK	8	DDC_DATA
9	L_BKLT_CTRL#	10	LCDEN
11	INV_ON	12	LVDS_DETECT#_C
13	LVDSA_D1P/eDP_1P	14	LVDSA_D0P/eDP_HPD
15	LVDSA_D1N/eDP_1N	16	LVDSA_D0N
17	GND	18	GND
19	LVDSA_D3P	20	LVDSA_D2P/EDP_OP
21	LVDSA_D3N	22	LVDSA_D2N/EDP_ON
23	GND	24	GND
25	LVDSB_1P	26	LVDSB_D0P
27	LVDSB_1N	28	LVDSB_D0N
29	GND	30	GND
31	LVDSB_D3P	32	LVDSB_D2P
33	LVDSB_D3N	34	LVDSB_D2N
35	GND	36	GND
37	LVDSCLKAP/eDPAUXP	38	LVDSCLKBP
39	LVDSCLKAN/eDPAUXN	40	LVDSCLKBN

2.3.9 LED Backlight Driver Wafer, 1*6P, 1.25mm

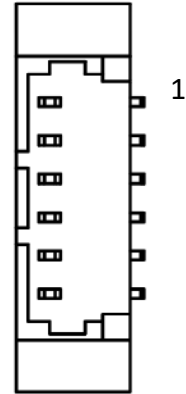
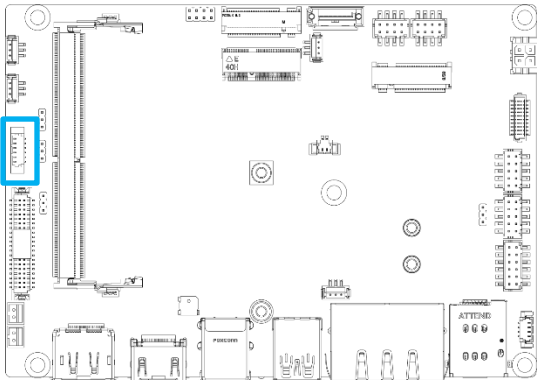

Pin	Definition
1	+5V Default/+12V
2	+5V Default/+12V
3	INV_ON
4	LCD_BKLT_CTRL#
5	GND
6	GND

2.3.10 COM1/2:2X10P Wafer 1.0mm

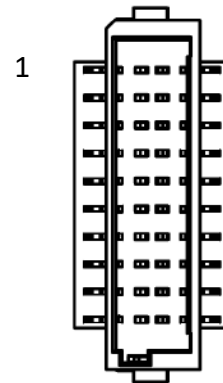
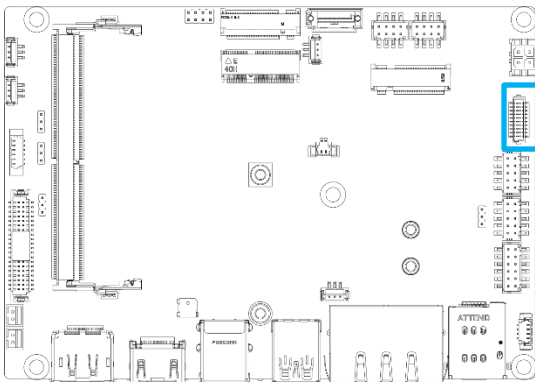

JCOM1/2

Pin	Definition	Pin	Definition
1	COM1_RS232_DCD/ COM1_RS422_TXD-/ COM1_RS485_TXD-	2	COM2_RS232_DCD
3	COM1_RS232_RXD/ COM1_RS422_TXD+/ COM1_RS485_TXD+	4	COM2_RS232_RXD/
5	COM1_RS232_TXD/ COM1_RS422_RXD+	6	COM2_RS232_TXD/
7	COM1_RS232_DTR/ COM1_RS422_RXD-	8	COM2_RS232_DTR/
9	GND	10	GND
11	COM1_RS232_DSR	12	COM2_RS232_DSR
13	COM1_RS232_RTS	14	COM2_RS232_RTS
15	COM1_RS232_CTS	16	COM2_RS232_CTS
17	COM1_RS232_RI	18	COM2_RS232_RI
19	N/C	20	N/C

2.3.11 OOB1:1X5 WAFER, 1.25mm

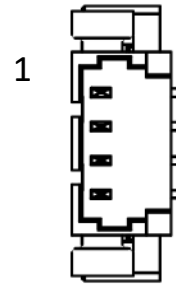
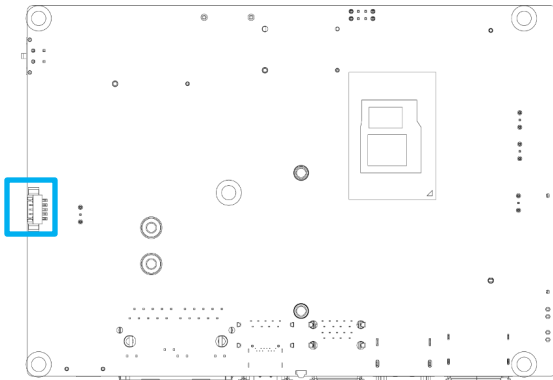

OOB1

Pin	Definition
1	+V5A
2	GND
3	Power on+
4	RESET_BUT_N
5	Power_ON_OFF

OOB2: For OOB debug, Wafer, 1*3P, 1.5mm

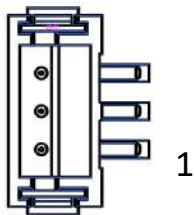

Pin	Definition
1	RX
2	TX
3	GND

OOB3: For Auto Link, Wafer, 1*3P, 1.5mm

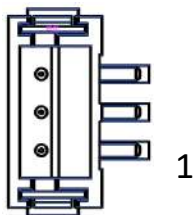

Pin	Definition
1	RX
2	TX
3	GND

2.3.12 SIM Support Dual nano SIM card

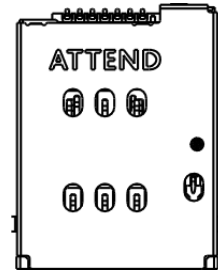
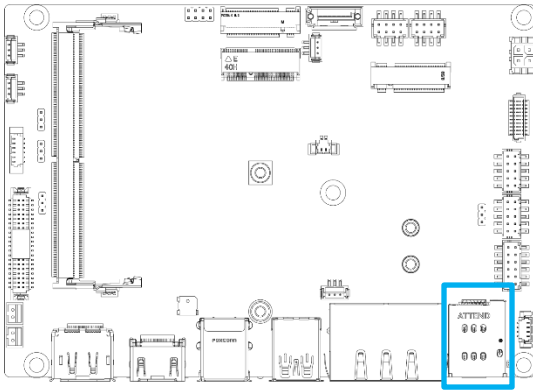

SIM1

Pin	Definition	Pin	Definition
C1	VCC1	C8	VCC2
C2	RST1	C9	RST2
C3	CLK1	C10	CLK2
CD1	CD1	CD2	CD2
C5	GND1	C12	GND2
C6	VPP1	C13	VPP2

2.3.13 SATA

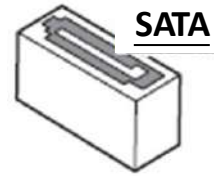
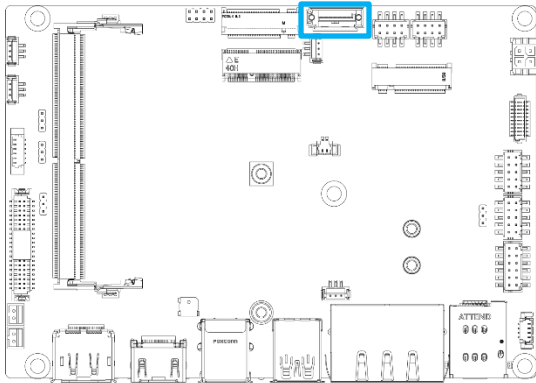

Pin	Definition
S1	GND
S2	SATA_TXP
S3	SATA_TXN
S4	SATAPCIE
S5	SATA_RXN
S6	SATA_TXP
S7	GND

2.3.14 SATA power: Wafer, 1*3P, 1.5mm

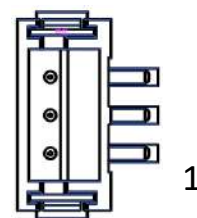
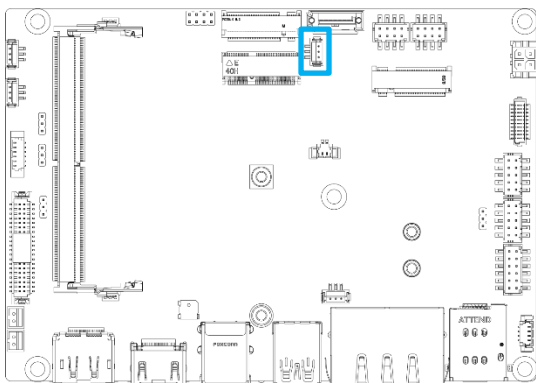

Pin	Definition
1	+5V
2	GND
3	+5V

2.3.15 JAUDIO1: Wafer, 6x2p, 2.00mm

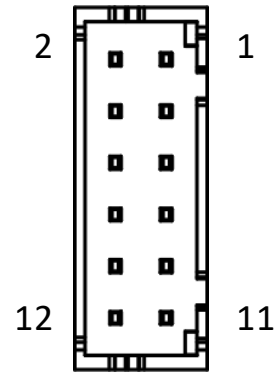
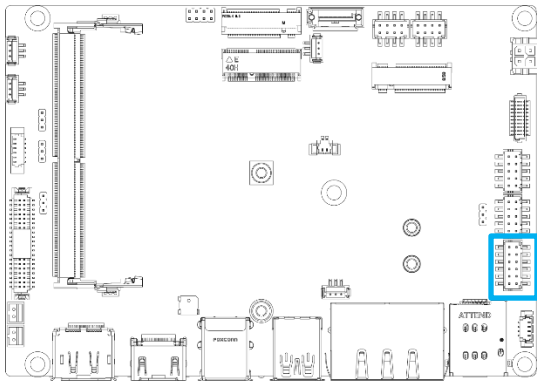

JAUDIO1

Pin	Definition	Pin	Definition
1	LINE_IN_RA	2	MIC1_RA
3	LINE_IN_LA	4	MIC1_LA
5	LOUT_RA	6	MIC_JD
7	LOUT_LA	8	LINE1_JD
9	FRONT_JD	10	GND
11	GND	12	GND

2.3.16 Left+Right Amplifier :Wafer, 4*1P 1.25mm

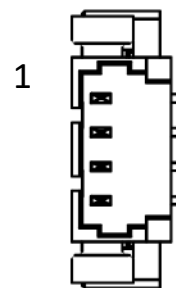
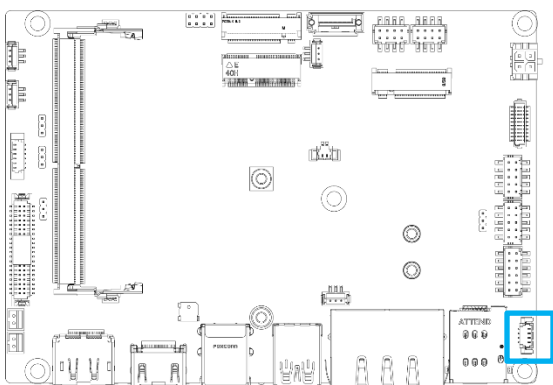

Pin	Definition
1	L_OUT-_B
2	L_OUT+_B
3	R_OUT-_B
4	R_OUT+_B

Chapter 3

System BIOS

3.1 BIOS Introduction

The BIOS provides an interface to modify the configuration. When the battery is removed, all the parameters will be reset.

BIOS Setup

Power on the embedded system and by pressing immediately allows you to enter the setup screens. If the message disappears before you respond and you still wish to enter the Setup, restart the system by turning it OFF and ON or pressing the RESET button.

You may also restart the system by simultaneously pressing <Ctrl>, <Alt>, and <Delete> keys.

Control Keys	
<→><←>	Select Screen
<↑><↓>	Select Item
<Enter>	Select
<Page Up/+>	Increases the numeric value or makes changes
<Page Down/->	Decreases the numeric value or makes changes
<F1>	General Help
<F2>	Previous Value
<F3>	Load Optimized Defaults
<F4>	Save Configuration and Exit
<Tab>	Select Setup Fields
<Esc>	Exit BIOS Setup

Main Setup

The main menu lists the setup functions you can make changes to. You can use the arrow keys (↑↓) to select the item. The on-line description of the highlighted setup function is displayed at the bottom of the screen.

General Help <F1>

The BIOS setup program provides a General Help screen. You can call up this screen from any menu by simply pressing <F1>. The Help screen lists the appropriate keys to use and the possible selections for the highlighted item. Press <Esc> to exit the Help screen.

3.2 Main Setup

Press to enter BIOS CMOS Setup Utility. The Main setup screen is showed as following when the setup utility is entered. System Date/Time is set up in the Main Menu.

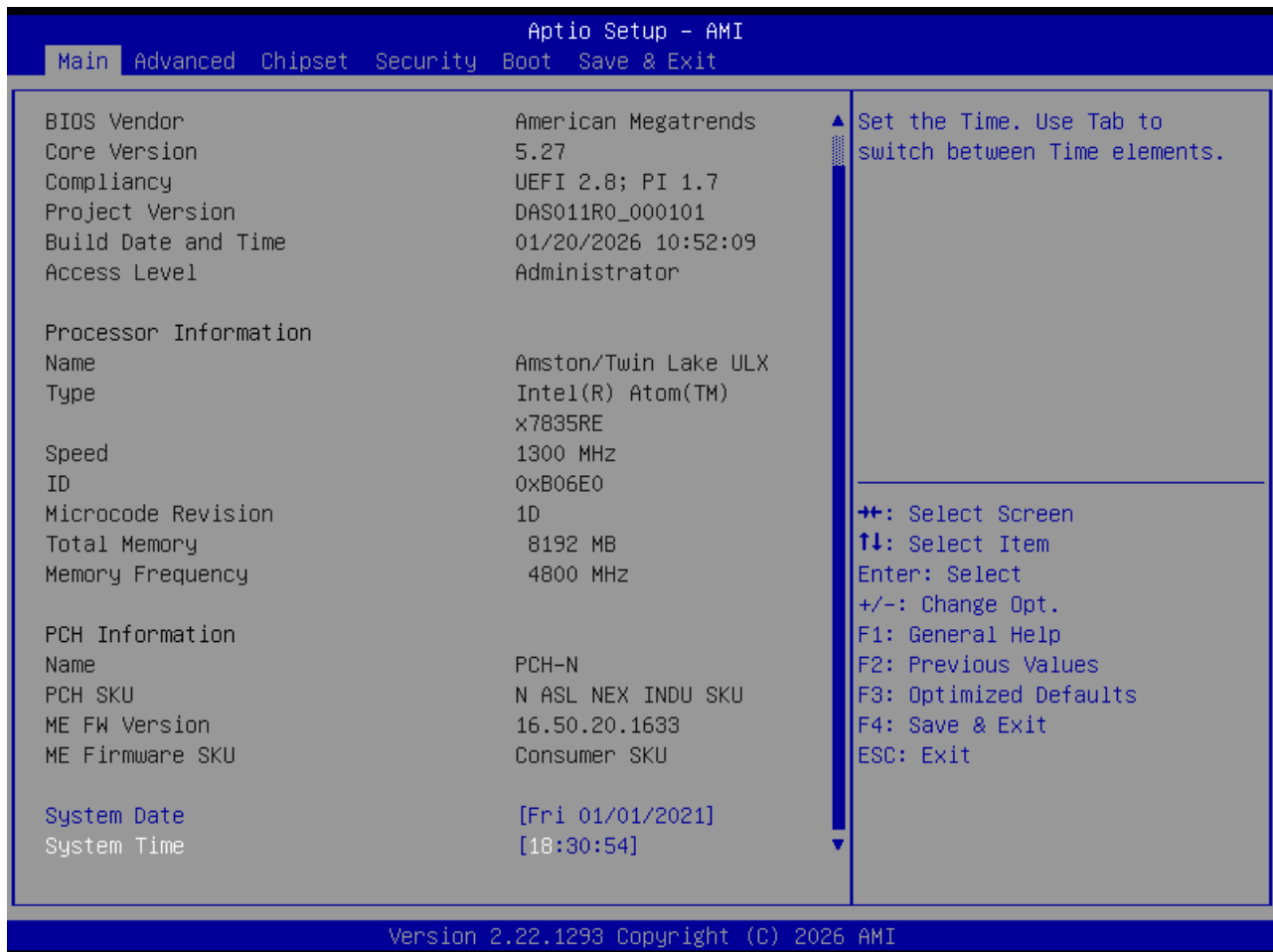

■ System Date

Set the system date. Please use <Tab> to switch between data elements.

■ System Time

Set the system time. Please use <Tab> to switch between time elements.

3.3 Advanced Setup

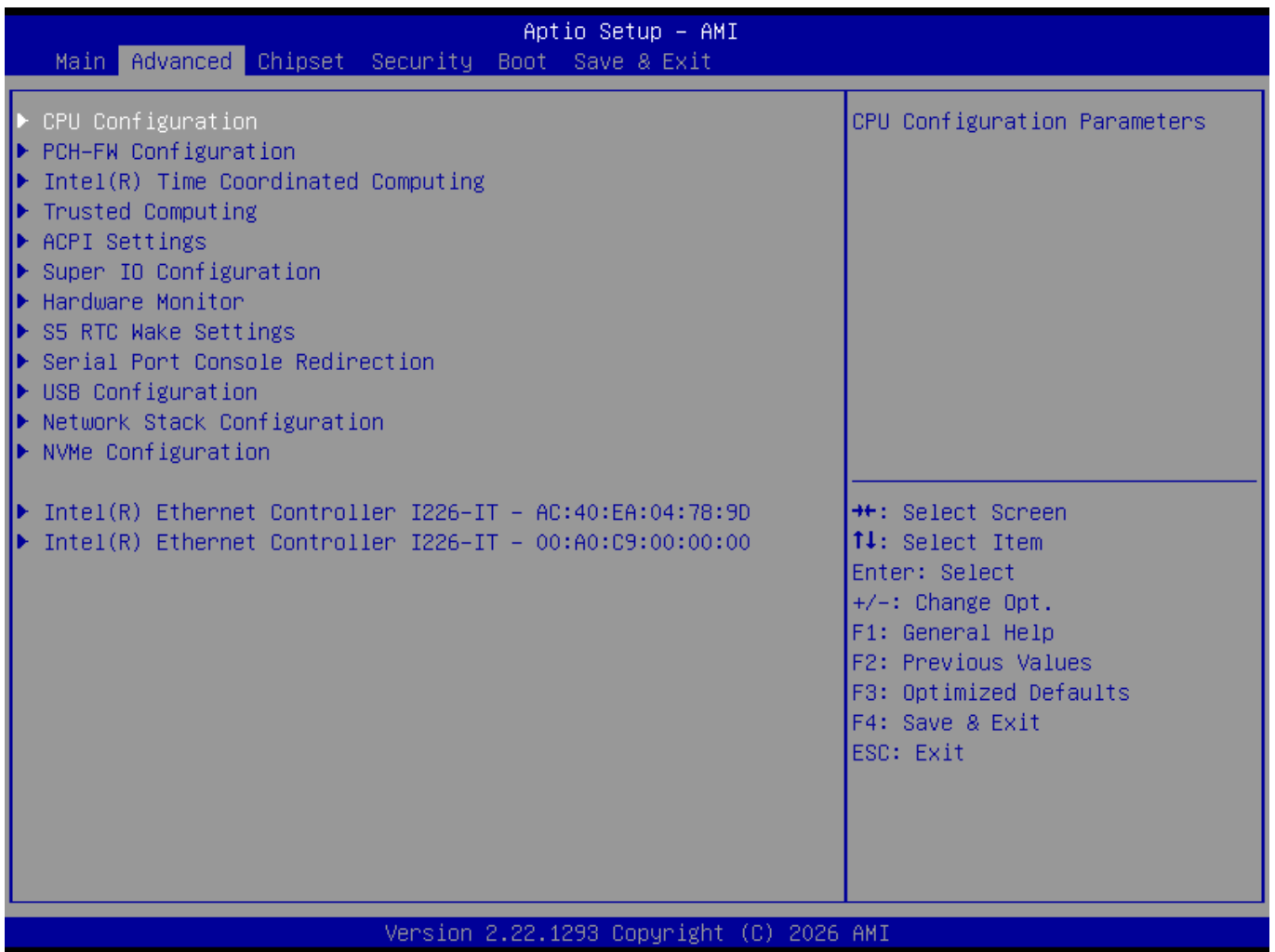

3.3.1 CPU Configuration

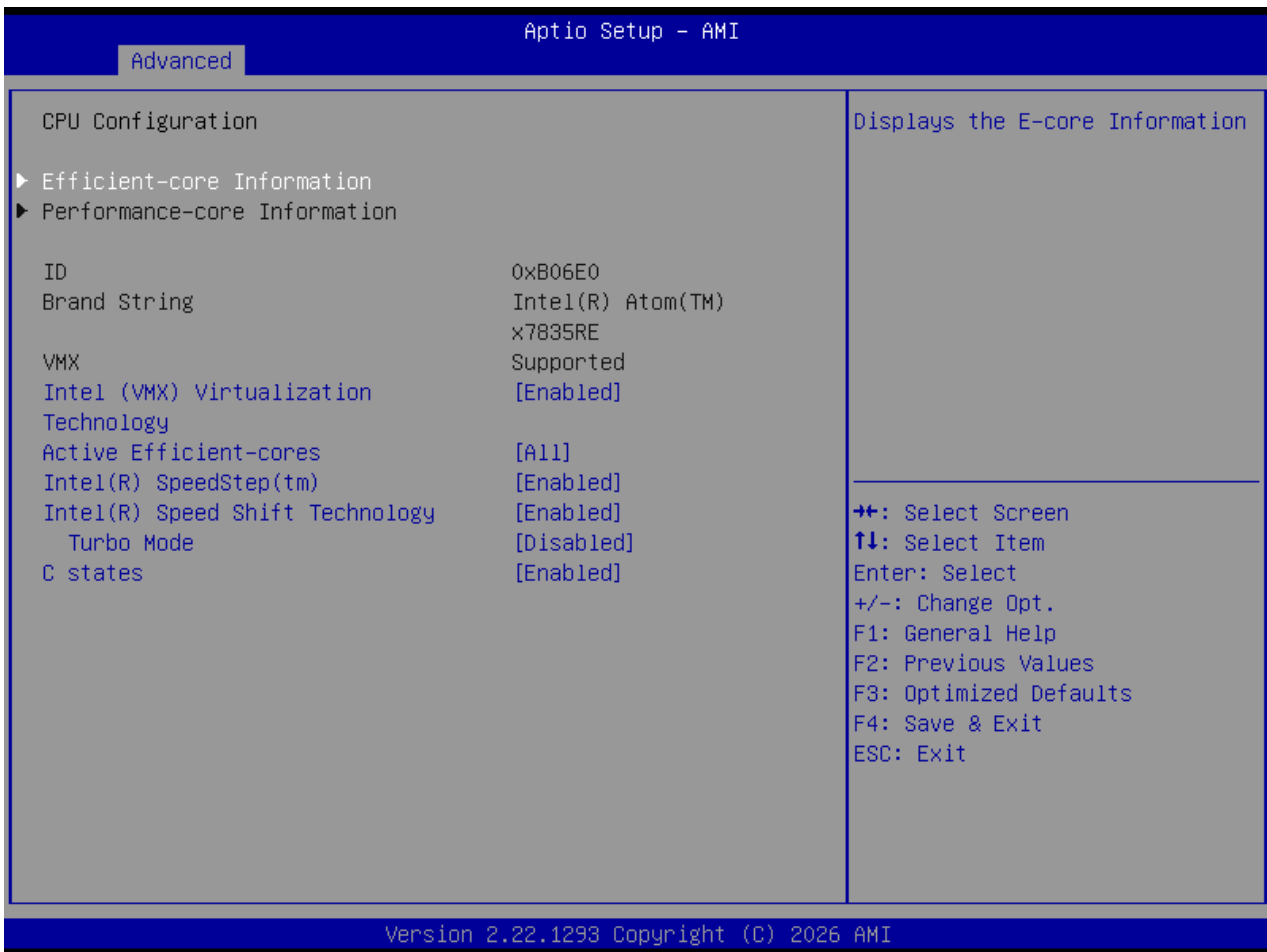

Item	Options	Description
Intel (VMX) Virtualization Technology	Disabled, Enabled[Default]	When enabled, a VMM can utilize the additional hardware capabilities provided by Virtualization Technology.
Active Processor Cores	All[Default] 0 1 2 3	Number of cores to enable in each processor package.
Intel® SpeedStep™	Disabled, Enabled[Default]	Allows more than two frequency ranges to be supported.
Intel® Speed Shift Technology	Disabled, Enabled[Default]	Enable/Disable Intel® Speed Shift Technology support. Enabling will expose the CPPC v2 interface to allow for hardware controlled P-states.
Turbo Mode	Disabled[Default], Enabled	Enable/Disable processor Turbo Mode (requires EMTM enabled too). AUTO means enabled.
C states	Disabled, Enabled[Default]	Enable/Disable CPU Power Management. Allows CPU to go to C states when it's not 100% utilized.

■ Efficient-core Information

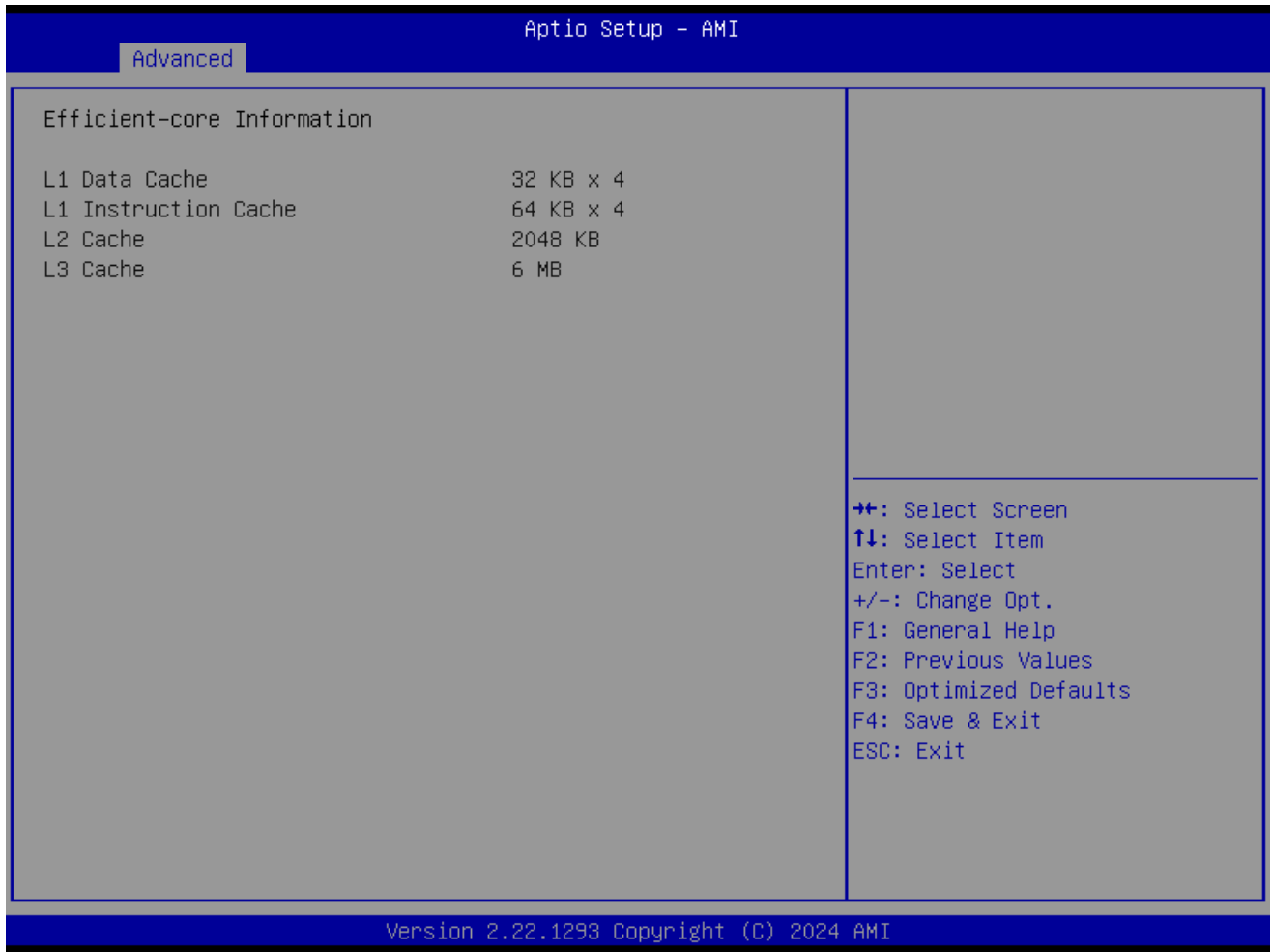

3.3.2 PCH-FW Configuration

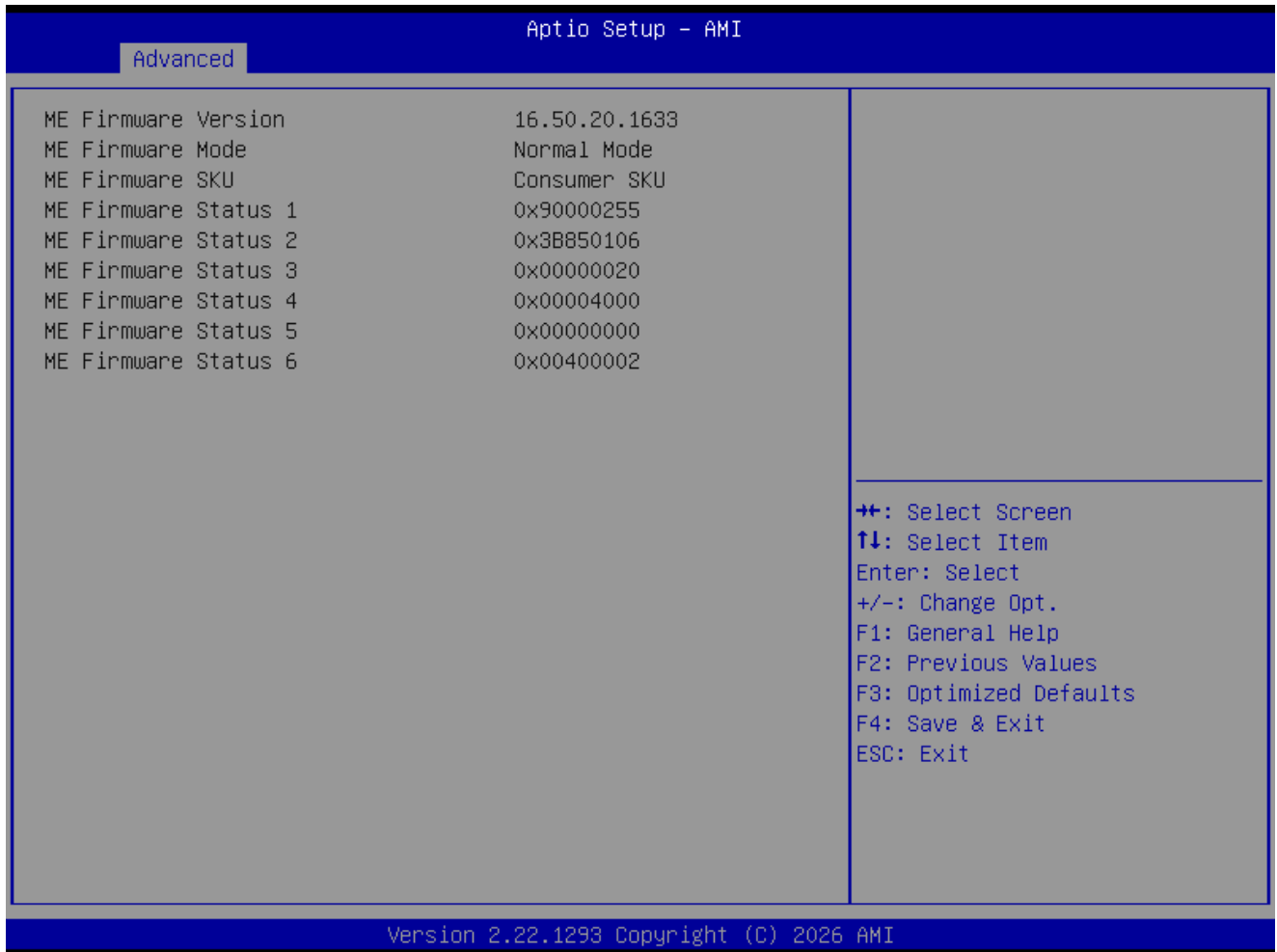

3.3.3 Intel® Time Coordinated Computing

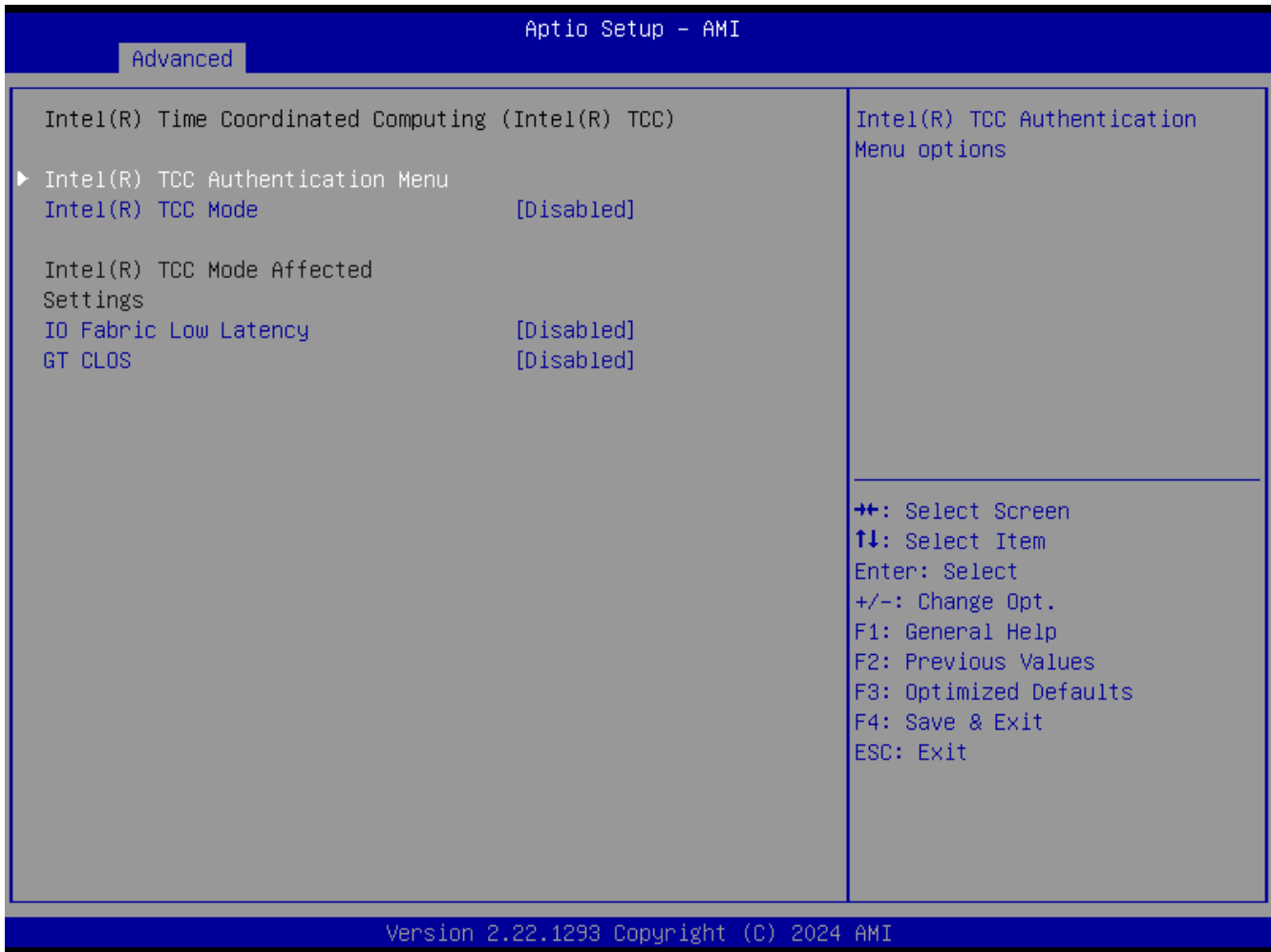

Item	Description
Intel® TCC Authentication Menu	Intel® TCC Authentication Menu options

Item	Options	Description
Intel® TCC Mode	Disabled[Default] , Enabled	Enable or Disable Intel® TCC Mode. When enabled, this will modify system settings to improve real-time performance. The full list of settings and their current state are displayed below when Intel® TCC mode is enabled.
IO Fabric Low Latency	Disabled[Default] , Enabled	Enable or Disable IO Fabric Low Latency. This will turn off some power management in the PCH IO fabrics. This option provides the most aggressive IO Fabric performance setting. S3 state is NOT supported.
GT CLOS	Disabled[Default] , Enabled	Enable or Disable Graphics Technology(GT) Class of Service. Enable will reduce Gfx LLC allocation to minimize impact of Gfx workload on LLC

■ Intel® TCC Authentication Menu

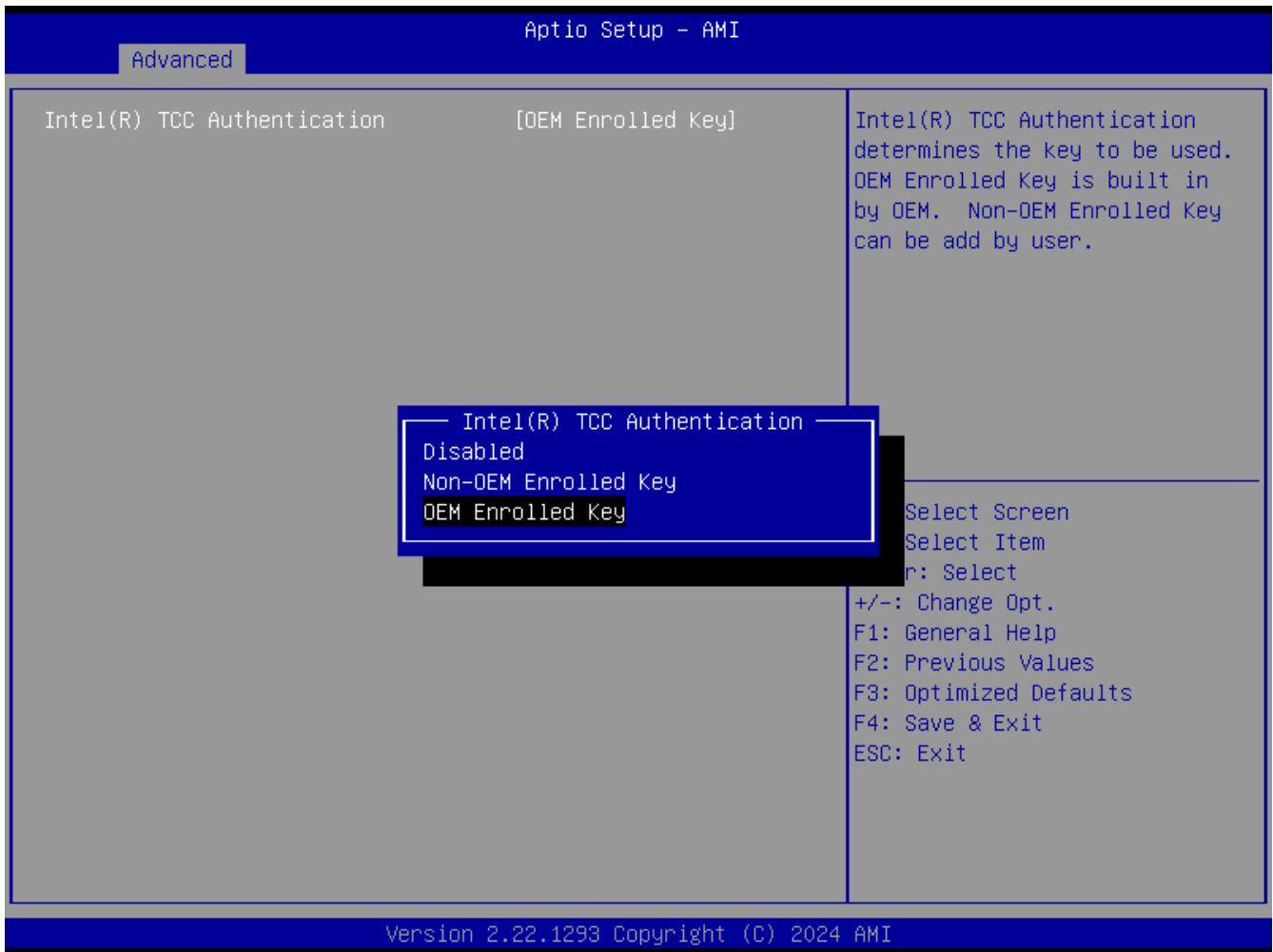

Item	Options	Description
Intel® TCC Authentication	Disabled, Non-OEM Enrolled Key, OEM Enrolled Key[Default]	Intel(R) TCC Authentication determines the key to be used. OEM Enrolled Key is built in by OEM. Non-OEM Enrolled Key can be add by user.

3.3.4 Trusted Computing

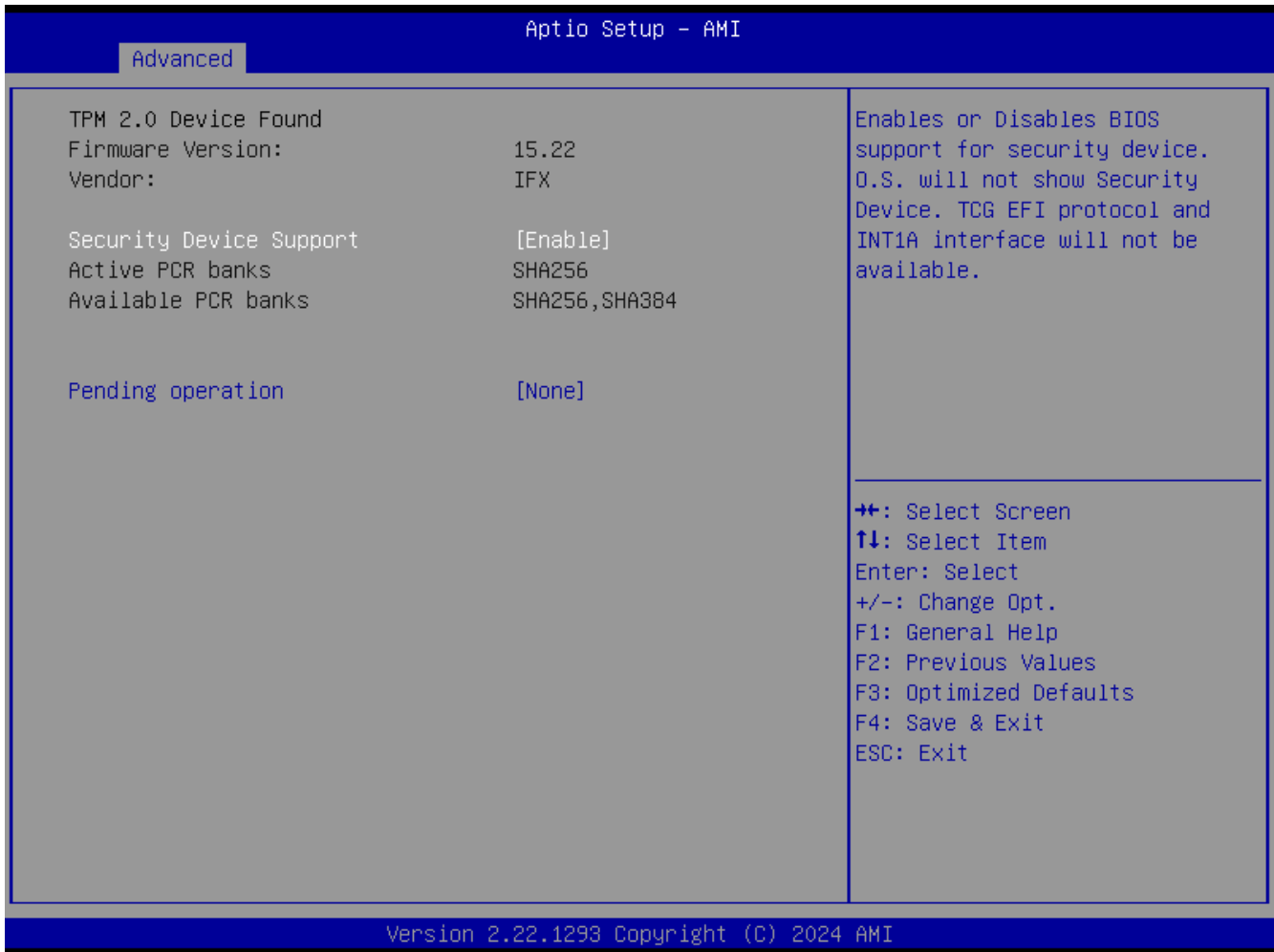

Item	Options	Description
Security Device Support	Enabled[Default] , Disabled,	Enable/Disable BIOS support for security device. O.S. will not show Security Device. TCG EFI protocol and INT1A interface will not be available.
Pending operation	None[Default] , TPM Clear	Schedule an Operation for the Security Device. NOTE: Your Computer will reboot during restart in order to change State of Security Device.

3.3.5 ACPI Settings

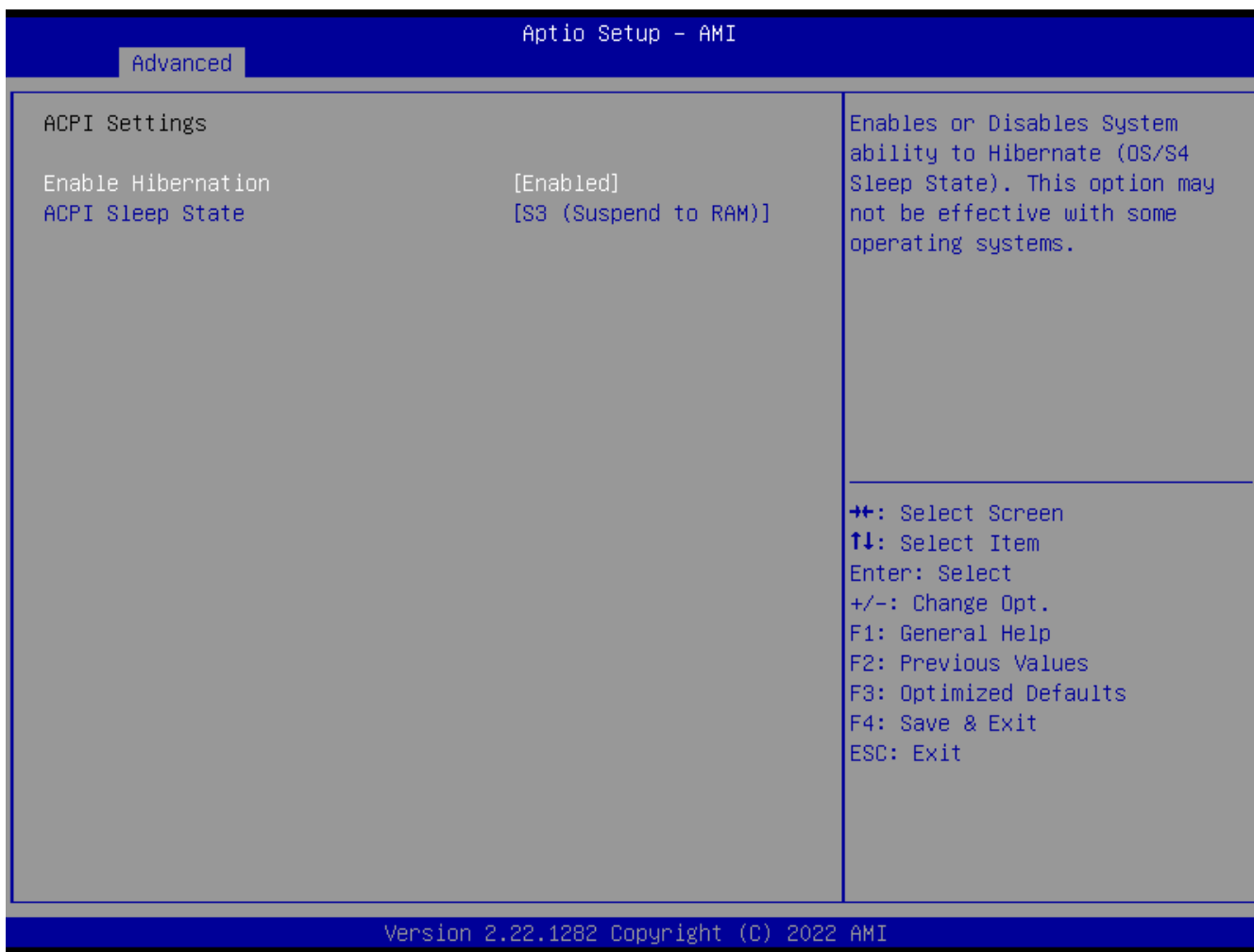

Item	Options	Description
Enable Hibernation	Disabled , Enabled [Default] ,	Enables or Disables System ability to Hibernate (OS/S4 Sleep State). This option may not be effective with some operating systems.
ACPI Sleep State	Suspend Disabled, S3 (Suspend to RAM) [Default]	Select the highest ACPI sleep state the system will enter when the SUSPEDN button is pressed.

3.3.6 Super IO Configuration

This setting allows you to select options for the Super IO Configuration, and change the value of the selected option.

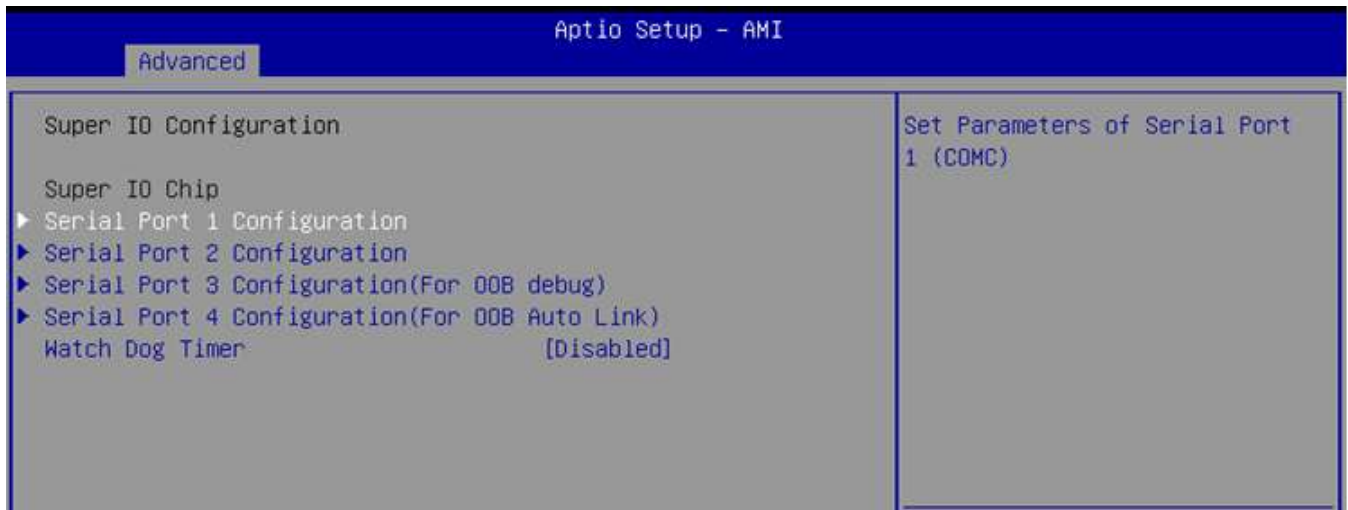

Item	Description
Serial Port 1 Configuration	Set Parameters of Serial Port 1 (COMA).
Serial Port 2 Configuration	Set Parameters of Serial Port 2 (COMB).
Serial Port 3 Configuration(For OOB debug)	Set Parameters of Serial Port 3 (COMC).
Serial Port 4 Configuration(For OOB Auto Link)	Set Parameters of Serial Port 4 (COMD).

Item	Options	Description
Watch Dog Timer	Disabled [Default], Enabled	Enabled or Disabled Watch Dog Timer function.
Watch Dog Timer Count Mode	Second Mode[Default], Minute Mode	Select Second Mode or Minute Mode.
Watch Dog Timer Time out Value	20~255(Second)[Default], 1~255(Minute)	Watch Dog Timer Time out. Second 20-255 Minute 1-255

	BIOS	Super IO	Windows_11 & 10 Device Manager	Ubuntu_24.04 & 22.04 sudo dmesg grep tty
User Manual_COM1	I/O=3F8h	com A	COM1 03F8-03FF	ttyS0 I/O=0x3f8
User Manual_COM2	I/O=2F8h	com B	COM2 02F8-02FF	ttyS1 I/O=0x2f8
User Manual_COM3	I/O=3E8h (For OOB debug)	com C	COM3 03E8-03EF	ttyS2 I/O=0x3e8
User Manual_COM4	I/O=2E8h (For OOB Auto Link)	com D	COM4 02E8-02EF	ttyS3 I/O=0x2e8

■ Serial Port 1 Configuration

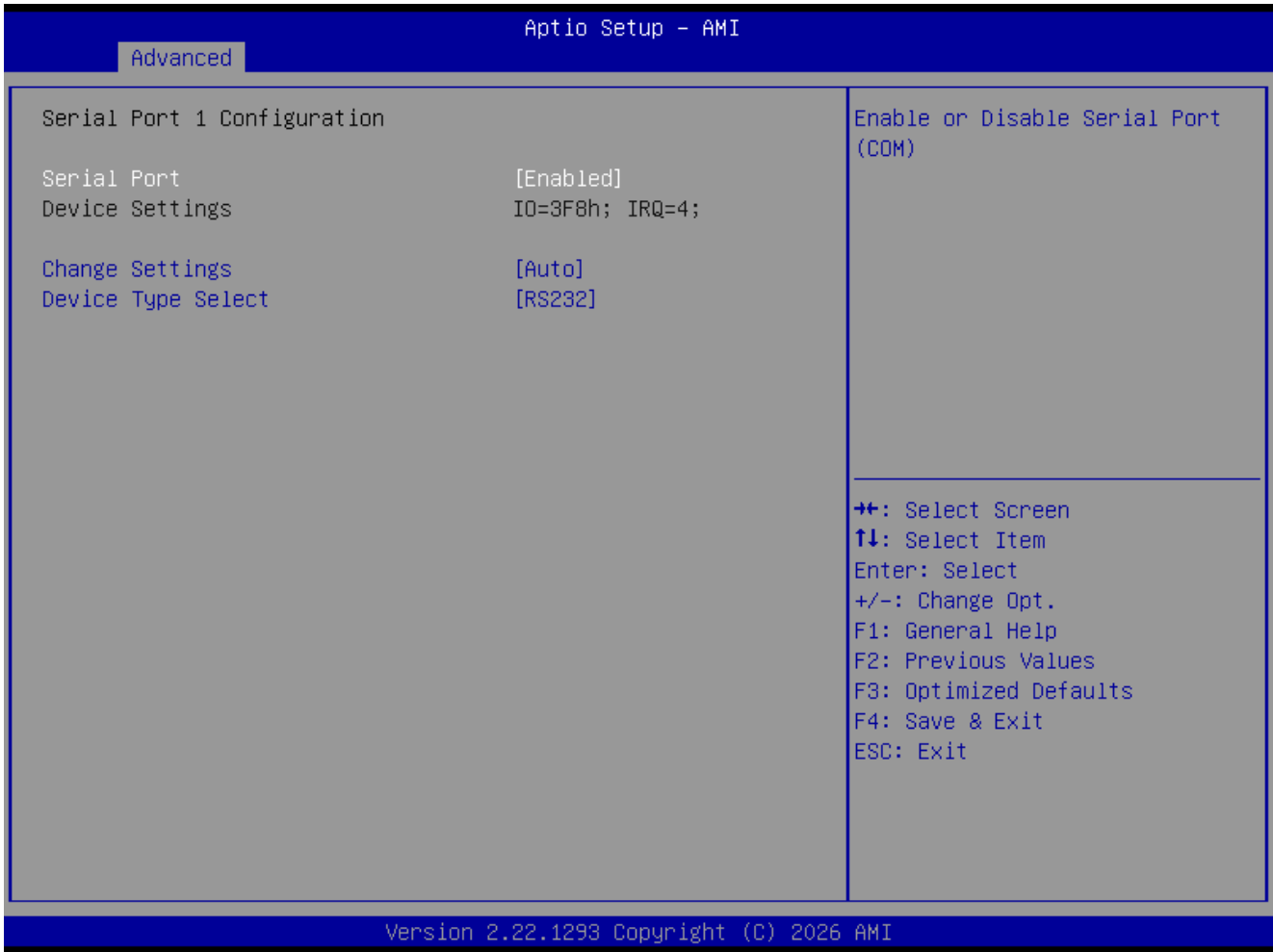

Item	Options	Description
Serial Port	Disabled, Enabled[Default]	Enable or Disable Serial Port (COM).
Change Settings	Auto[Default], IO=3Fh; IRQ=4; , IO=3F8h; IRQ=3,4,5,6,7,9,10,11,12; , IO=2F8h; IRQ=3,4,5,6,7,9,10,11,12;; IO=3E8h; IRQ=3,4,5,6,7,9,10,11,12;; IO=2E8h; IRQ=3,4,5,6,7,9,10,11,12;	Select an optimal settings for Super IO Device.

■ Serial Port 2 Configuration

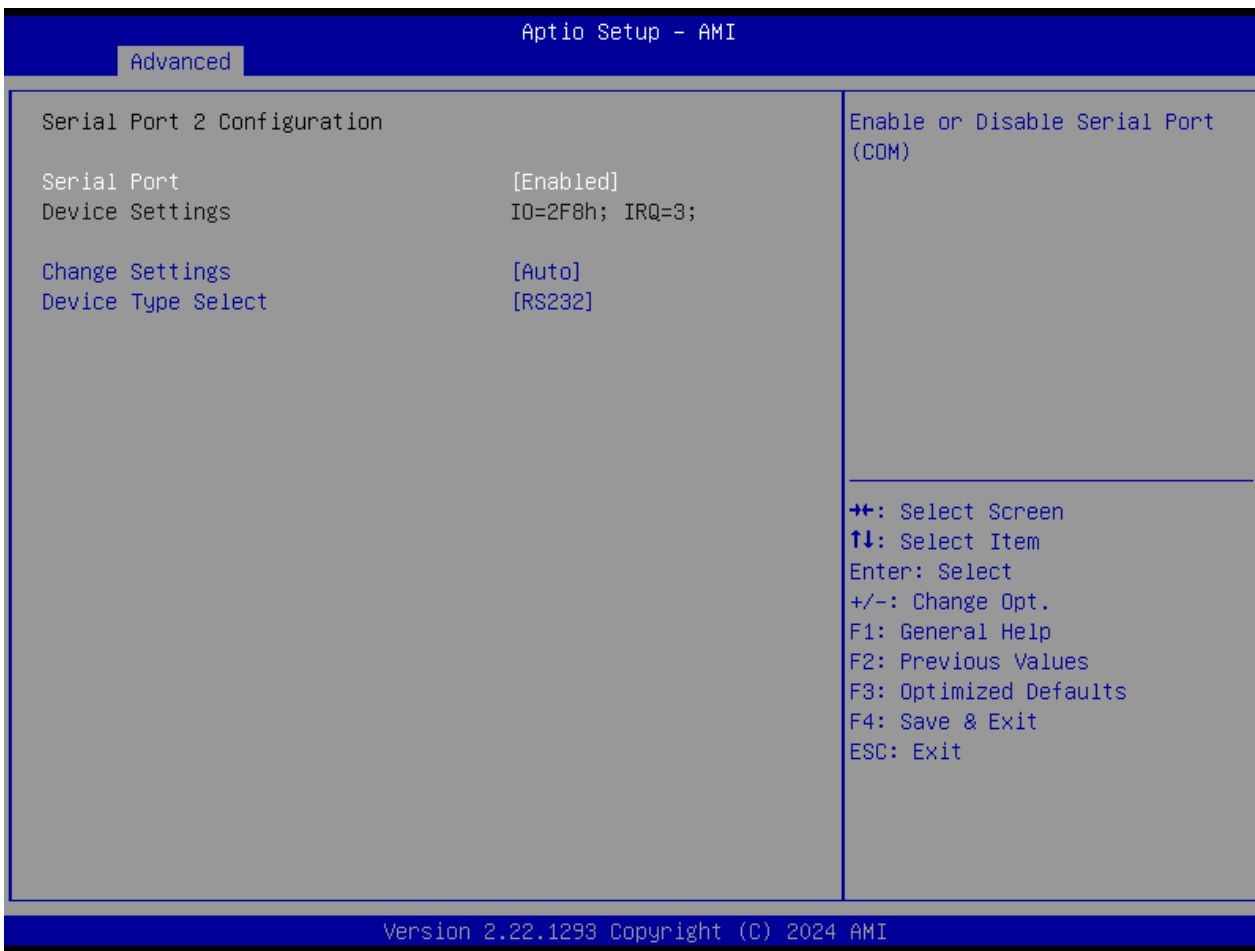

Item	Options	Description
Serial Port	Disabled, Enabled[Default]	Enable or Disable Serial Port (COM).
Change Settings	Auto[Default], IO=2F8h; IRQ=3; , IO=3F8h; IRQ=3,4,5,6,7,9,10,11,12; , IO=2F8h; IRQ=3,4,5,6,7,9,10,11,12;; IO=3E8h; IRQ=3,4,5,6,7,9,10,11,12;; IO=2E8h; IRQ=3,4,5,6,7,9,10,11,12;	Select an optimal settings for Super IO Device.
Device Type Select	RS232[Default], RS422, RS485	Set the Serial Port to RS232 & RS422 & RS485
RS-485 Auto Flow Function	Disabled, Enabled[Default]	Enabled/Disabled RS485 Autoflow Function

■ Serial Port 3 Configuration(For OOB debug)

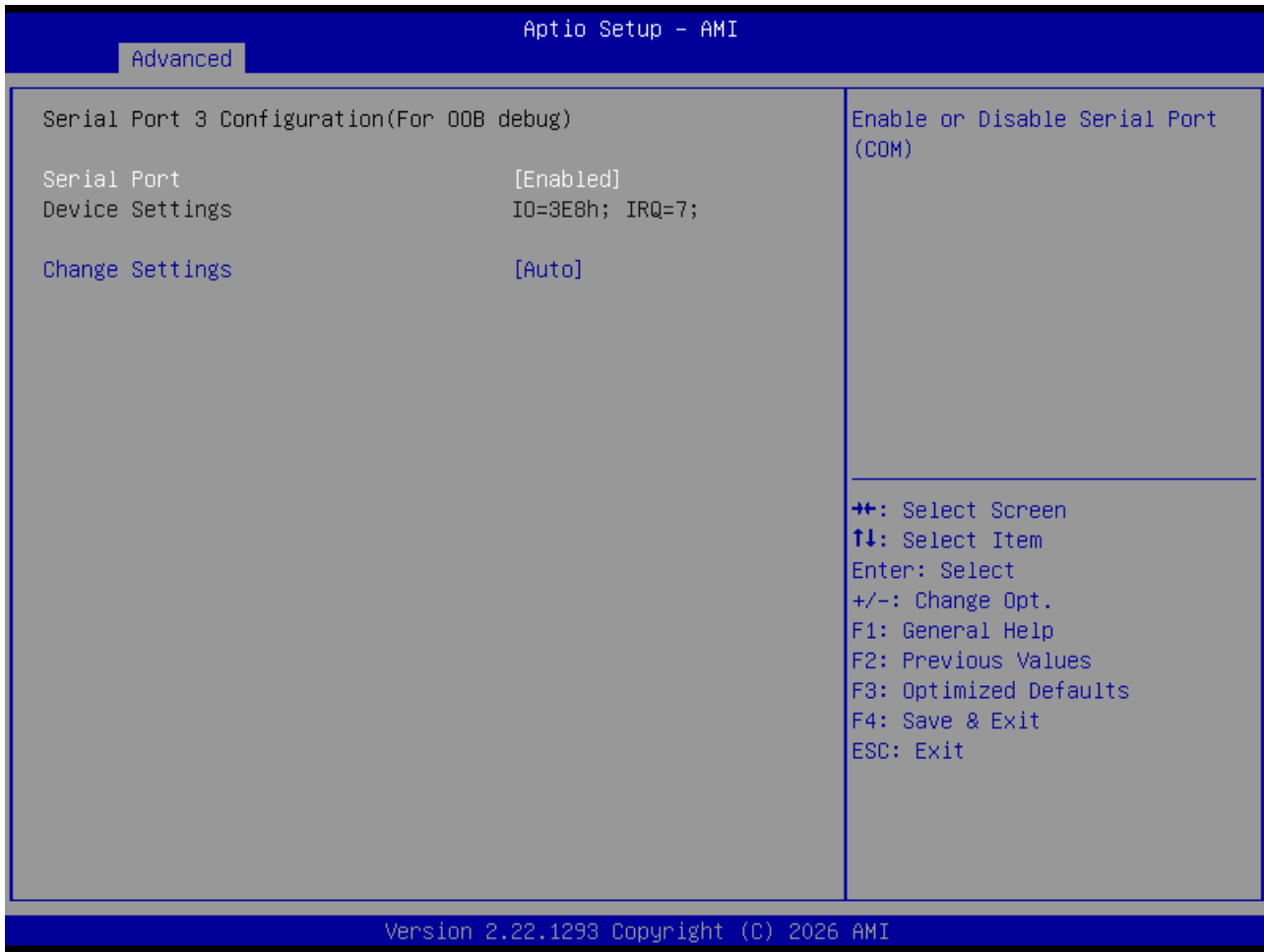

Item	Options	Description
Serial Port	Disabled, Enabled[Default]	Enable or Disable Serial Port (COM).
Change Settings	Auto[Default], IO=3E8h; IRQ=7; , IO=3E8h; IRQ=3,4,5,6,7,9,10,11,12;, IO=2E8h; IRQ=3,4,5,6,7,9,10,11,12;, IO=2F0h; IRQ=3,4,5,6,7,9,10,11,12;, IO=2E0h; IRQ=3,4,5,6,7,9,10,11,12;	Select an optimal settings for Super IO Device.

■ Serial Port 4 Configuration(For OOB Auto Link)

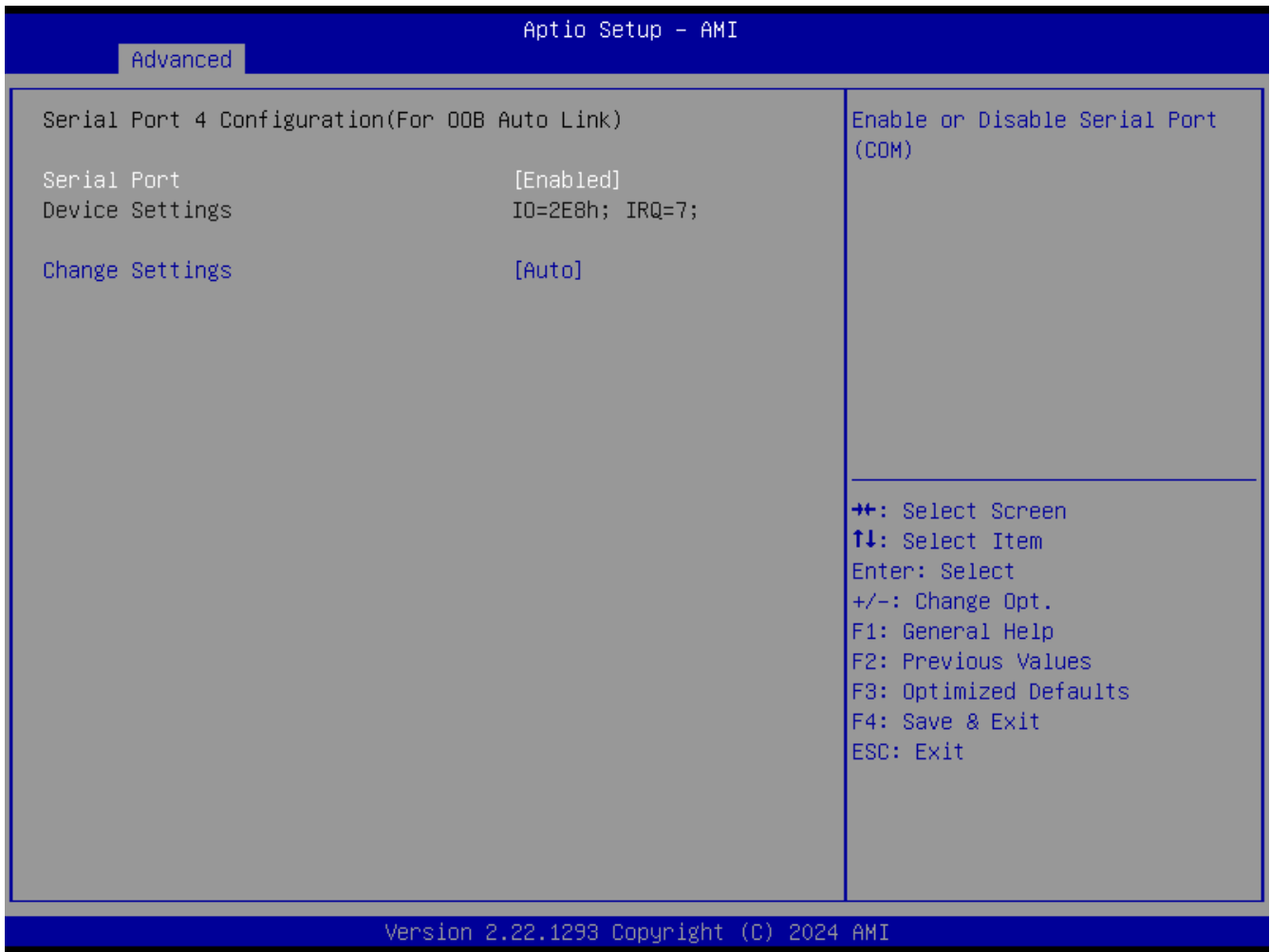

Item	Options	Description
Serial Port	Disabled, Enabled[Default]	Enable or Disable Serial Port (COM).
Change Settings	Auto[Default], IO=2E8h; IRQ=7; , IO=3E8h; IRQ=3,4,5,6,7,9,10,11,12; , IO=2E8h; IRQ=3,4,5,6,7,9,10,11,12;, IO=2F0h; IRQ=3,4,5,6,7,9,10,11,12;, IO=2E0h; IRQ=3,4,5,6,7,9,10,11,12;	Select an optimal settings for Super IO Device.

3.3.7 Hardware Monitor

These items display the current status of all monitored hardware devices/ components such as voltages and temperatures.

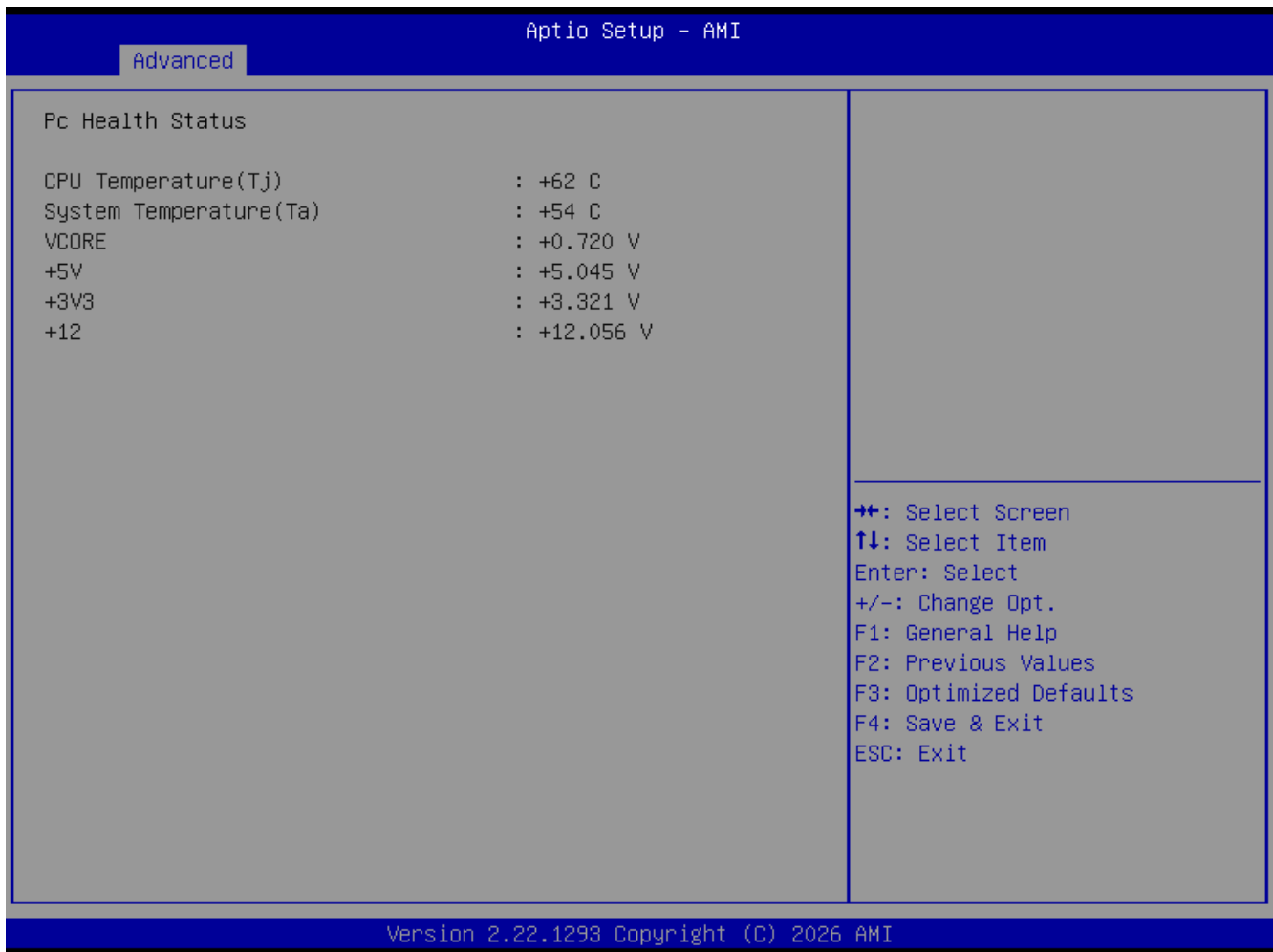

3.3.8 S5 RTC Wake Settings



Item	Options	Description
Wake system from S5	Disabled [Default] Fixed Time Dynamic Time ByPass	Enable or disable System wake on alarm event. Select FixedTime, system will wake on the hr::min::sec specified. Select DynamicTime , System will wake on the current time + Increase minute(s), Select Bypass : BIOS will not control RTC wake function during system shutdown

3.3.9 Serial Port Console Redirection

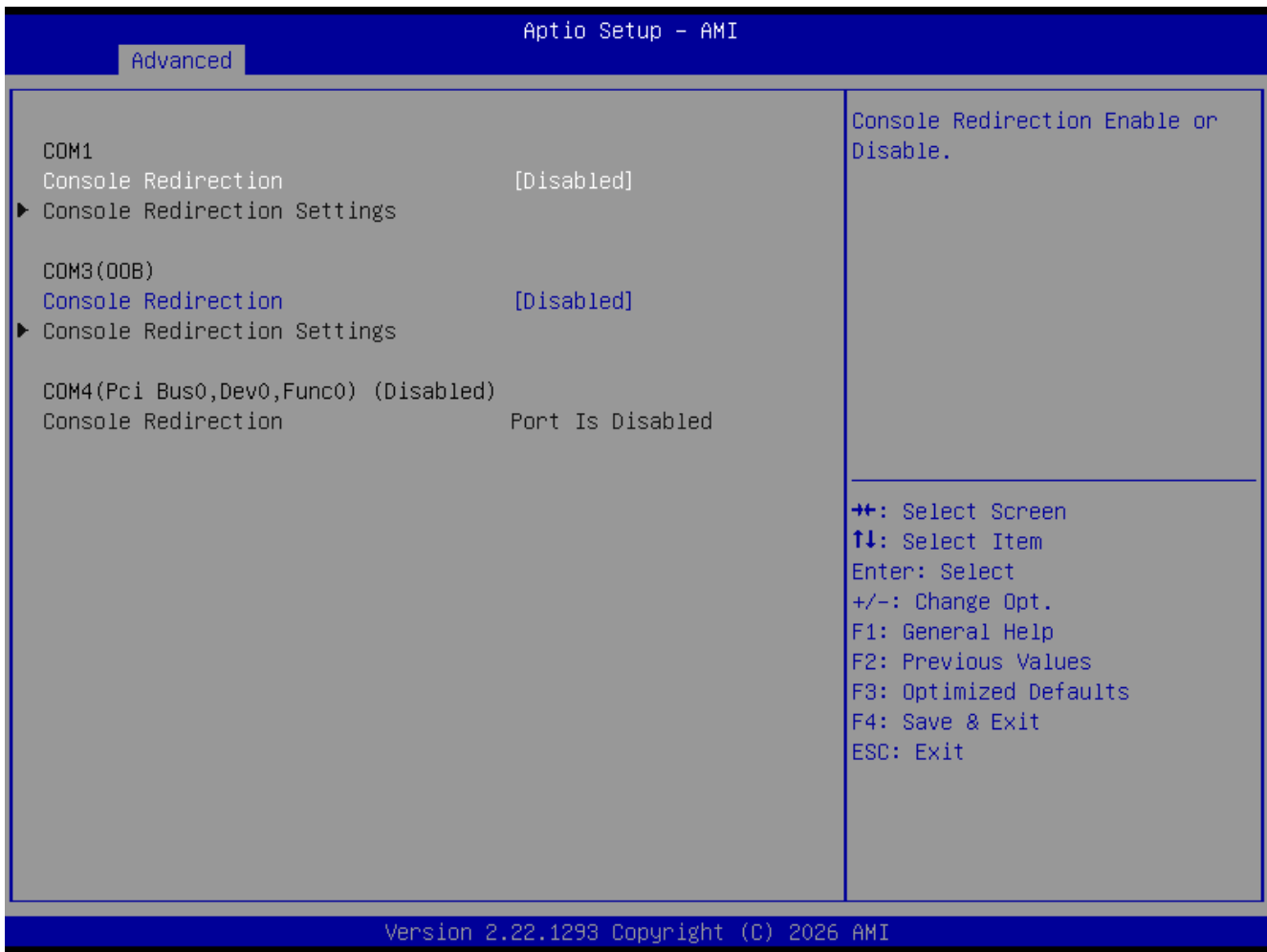

Item	Options	Description
Console Redirection	Disabled[Default], Enabled	Console Redirection Enable or Disable.

3.3.10 USB Configuration

Aptio Setup - AMI	
Advanced	
USB Configuration	Enables Legacy USB support. AUTO option disables legacy support if no USB devices are connected. DISABLE option will keep USB devices available only for EFI applications.
USB Module Version	32
USB Controllers:	
1 XHCI	
USB Devices:	
1 Drive, 1 Keyboard	
Legacy USB Support	[Enabled]
XHCI Hand-off	[Enabled]
USB Mass Storage Driver Support	[Enabled]
USB hardware delays and time-outs:	++: Select Screen ↑↓: Select Item Enter: Select +/-: Change Opt. F1: General Help F2: Previous Values F3: Optimized Defaults F4: Save & Exit ESC: Exit
USB transfer time-out	[20 sec]
Device reset time-out	[20 sec]
Device power-up delay	[Auto]
Mass Storage Devices:	
JetFlashTranscend 64GB 1100	[Auto]

Version 2.22.1293 Copyright (C) 2024 AMI

Item	Options	Description
Legacy USB Support	Enabled[Default], Disabled Auto	Enables Legacy USB support. AUTO option disables legacy support if no USB devices are connected. DISABLE option will keep USB devices available only for EFI applications.
XHCI Hand-off	Enabled[Default], Disabled	This is a workaround for OSeW without XHCI hand-off support. The XHCI ownership change should be claimed by XHCI driver.
USB Mass Storage Driver Support	Disabled, Enabled[Default]	Enable/Disable USB Mass Storage Driver Support.
USB transfer time-out	1 sec, 5 sec, 10 sec, 20 sec[Default]	The time-out value for Control, Bulk, and Interrupt transfers.
Device reset time-out	10 sec, 20 sec[Default], 30 sec, 40 sec	USB mass storage device Start Unit command time-out.
Device power-up delay	Auto[Default], Manual	Maximum time the device will take before it properly reports itself to the Host Controller. 'Auto' uses default value: for a Root port it is 100ms, for a Hub port the delay is taken from Hub descriptor.

3.3.11 Network Stack Configuration

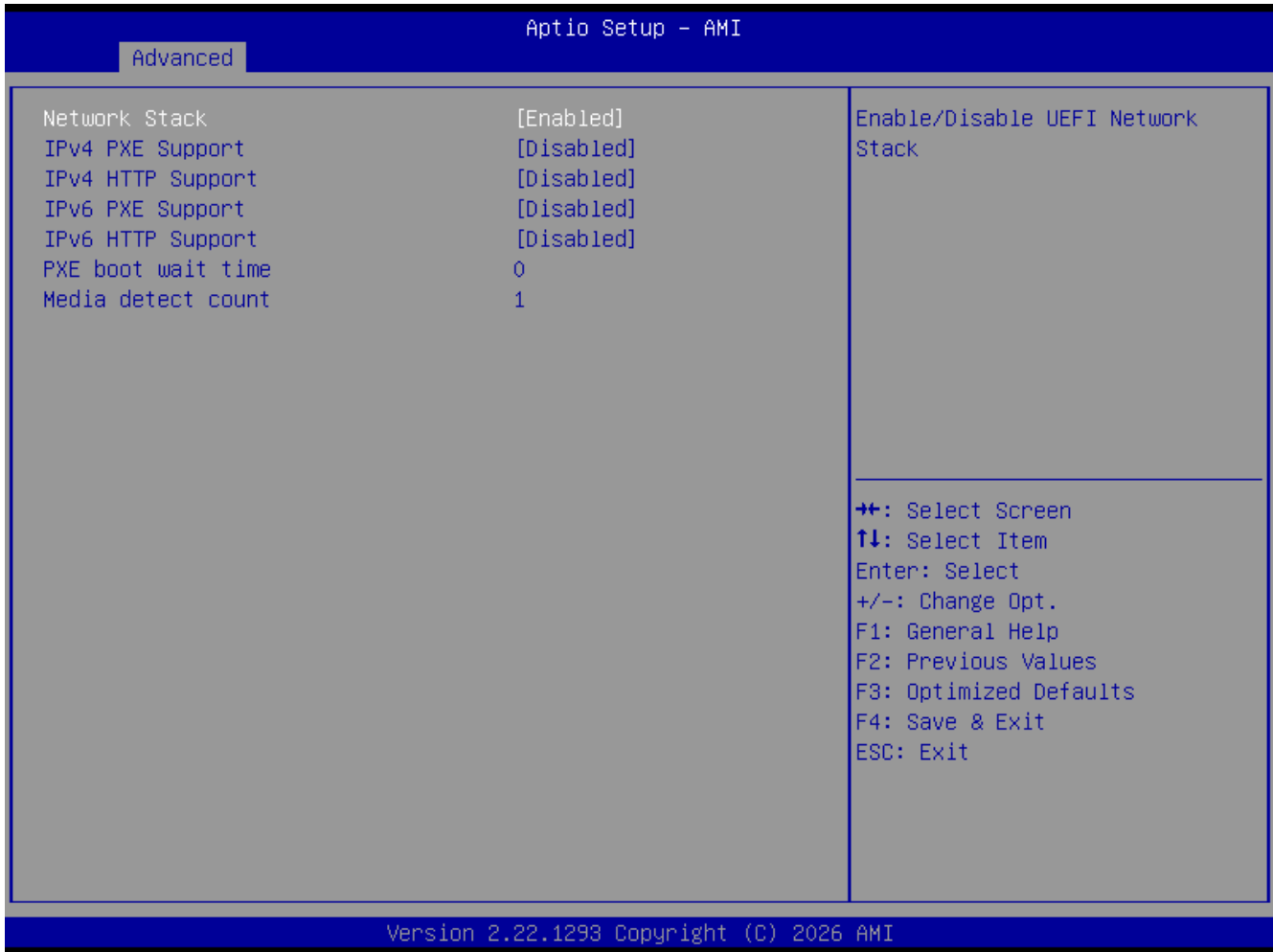

Item	Options	Description
Network Stack	Disabled[Default] , Enabled	Enable/Disable UEFI Network Stack.
IPv4 PXE Support	Disabled[Default] , Enabled	Enable/Disable IPv4 PXE boot support. If disabled, IPv4 PXE boot support will not be available.
IPv4 HTTP Support	Disabled[Default] , Enabled	Enable/Disable IPv4 HTTP boot support. If disabled, IPv4 HTTP boot support will not be available.
IPv6 PXE Support	Disabled[Default] , Enabled	Enable/Disable IPv6 PXE boot support. If disabled, IPv6 PXE boot support will not be available.
IPv6 HTTP Support	Disabled[Default] , Enabled	Enable/Disable IPv6 HTTP boot support. If disabled, IPv6 HTTP boot support will not be available.
PXE boot wait time	0	Wait time in seconds to press ESC key to abort the PXE boot. Use either +/- or numeric keys to set the value.
Media detect count	1	Number of times the presence of media will be checked. Use either +/- or numeric keys to set the value.

3.3.12 NVMe Configuration

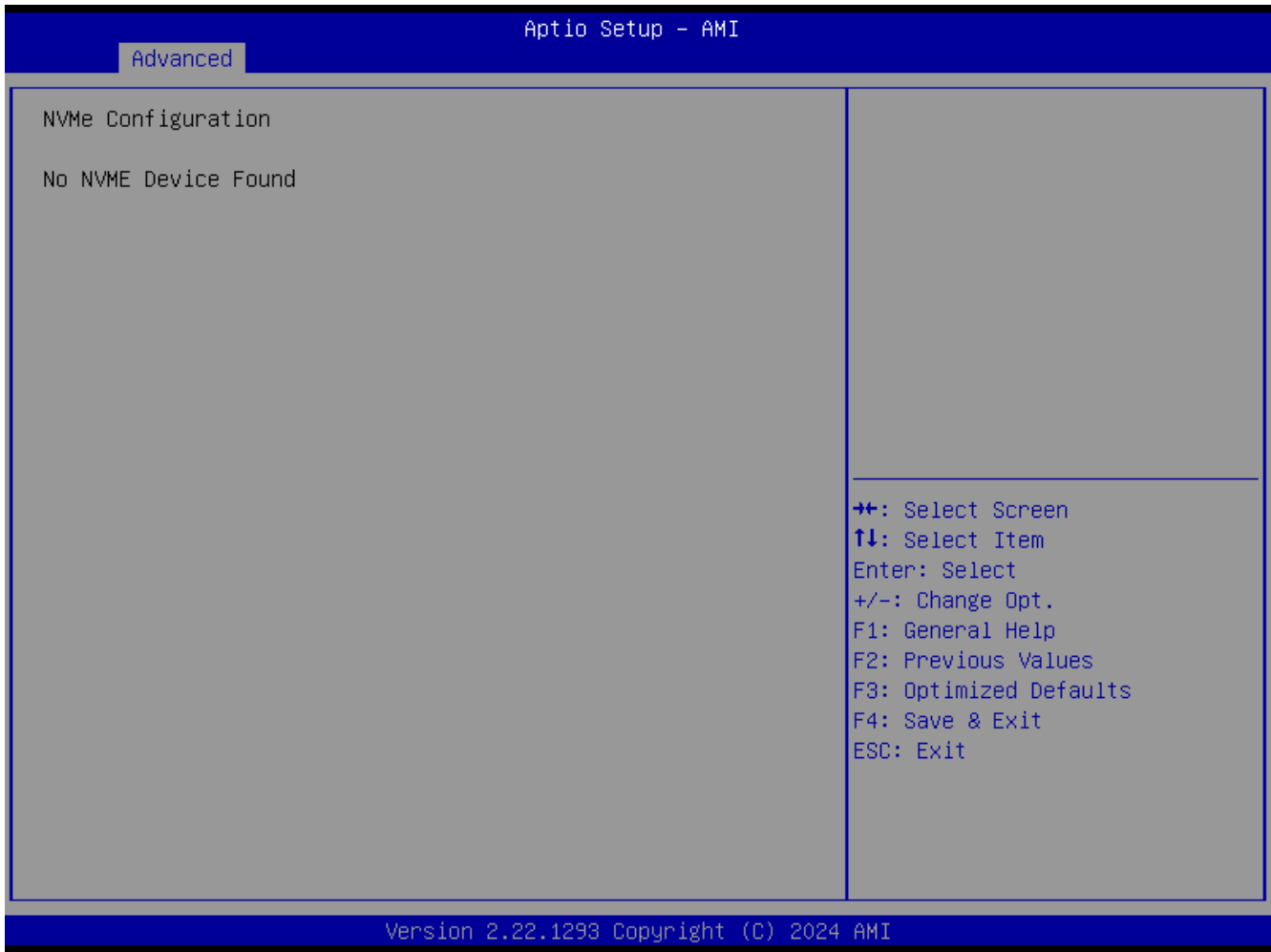

3.4 Chipset

This section allows you to configure and improve your system and allows you to set up some system features according to your preference.



3.4.1 System Agent (SA) Configuration



Item	Description
Memory Configuration	Memory Configuration Parameters
Graphics Configuration	Graphics Configuration

Item	Options	Description
Above 4GB MMIO BIOS assignment	Enabled[Default] , Disabled	Enable/Disable above 4GB MemoryMappedIO BIOS assignment\n\nThis is enabled automatically when Aperture Size is set to 2048MB.

■ Memory Configuration

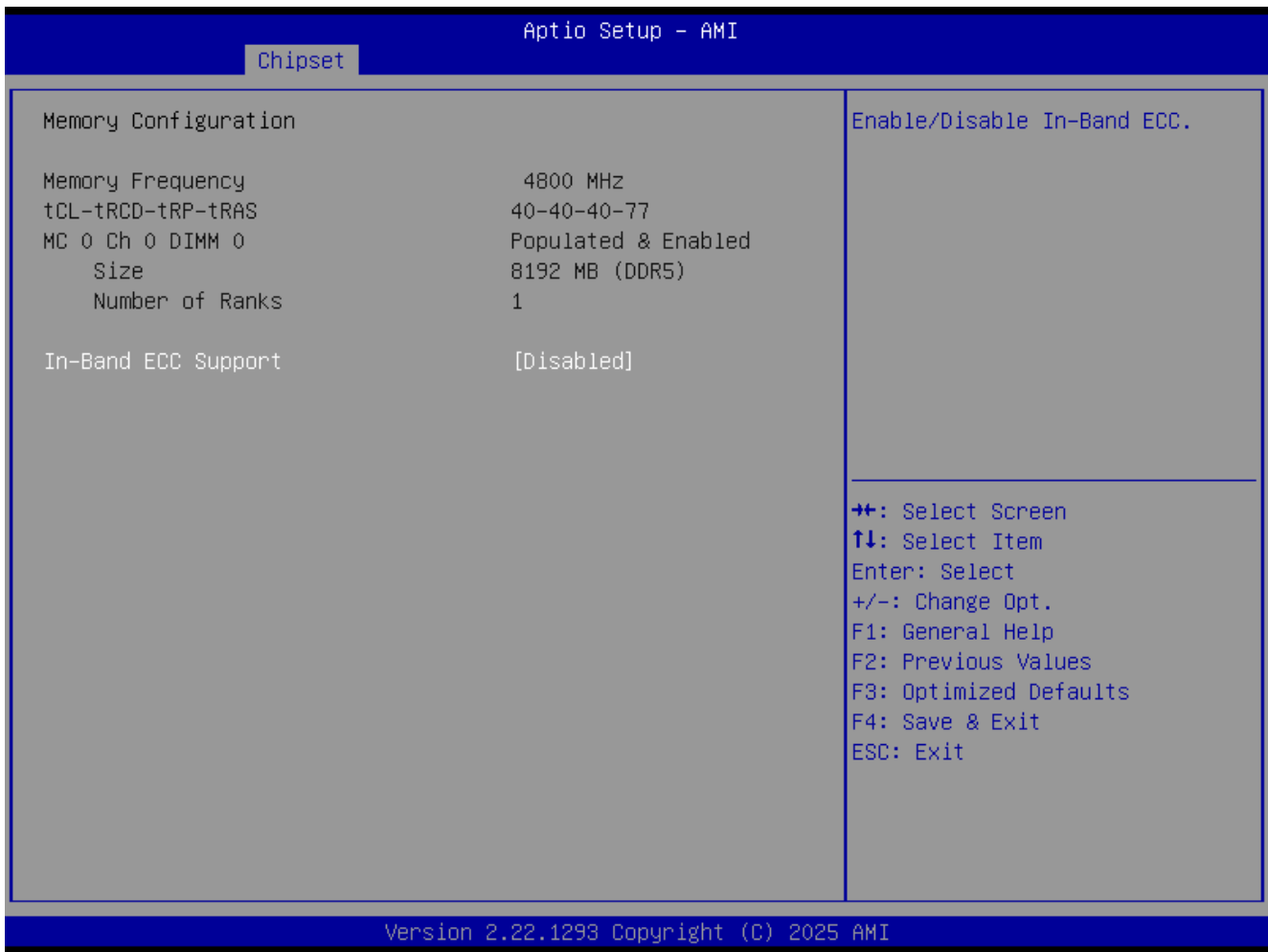

Item	Options	Description
In-Band ECC Support	Disabled[Default], Enabled	Enable/Disable In-Band ECC.

■ Graphic Configuration

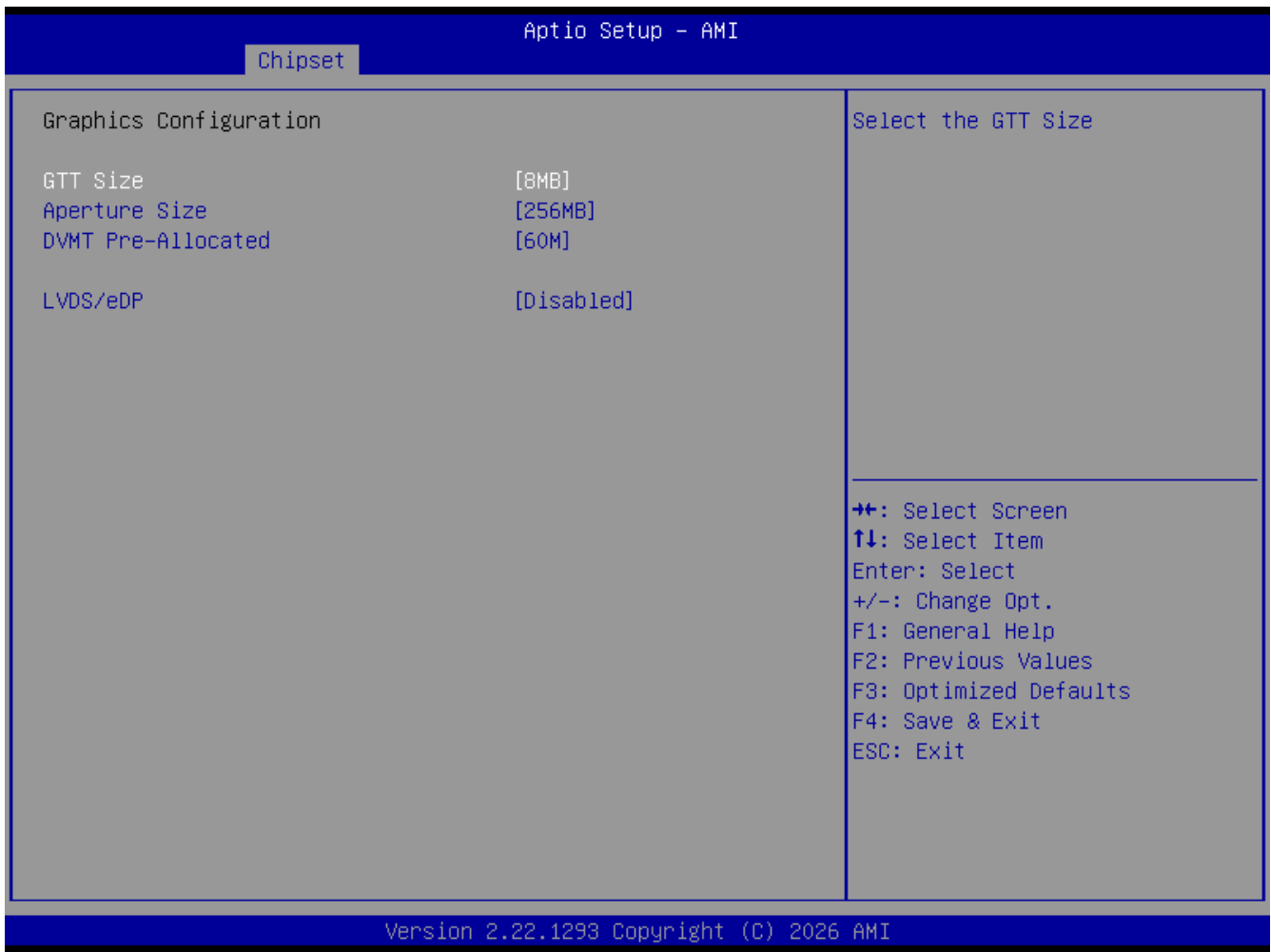

Item	Options	Description
GTT Size	2MB, 4MB, 8MB[Default]	Select the GTT Size .
Aperture Size	128MB, 256MB[Default] , 512MB, 1024MB	Select the Aperture Size. Note : Above 4GB MMIO BIOS assignment is automatically enabled when selecting > 2048MB aperture. To use this feature, please disable CSM Support.
DVMT Pre-Allocated	32M,64M,96M,128M, 160M, 36M, 40M,44M, 48M,52M,56M, 60M[Default]	Select DVMT 5.0 Pre-Allocated (Fixed) Graphics Memory size used by the Internal Graphics Device.
LVDS/eDP	Disabled[Default], LVDS, eDP	Please select one Panel type

3.4.2 PCH-IO Configuration

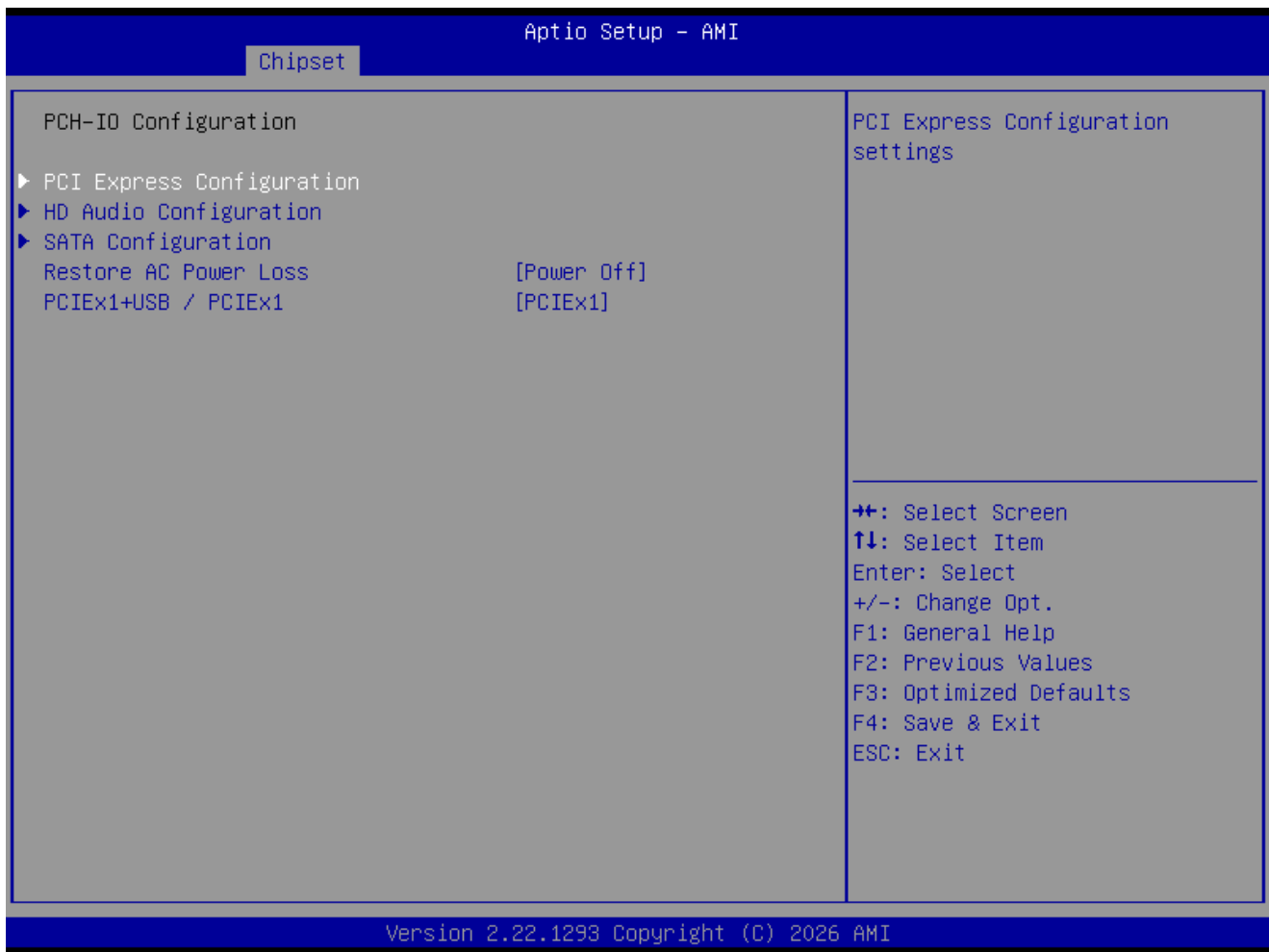

Item	Description
PCI Express Configuration	PCI Express Configuration settings.
HD Audio Configuration	HD Audio Subsystem Configuration Settings

Item	Options	Description
Restore AC Power Loss	Power On, Power Off [Default] , Lase State	Specify what state to go to when power is re-applied after a power failure (G3 state).
PCIEx1+USB / PCIEx1	PCIEx1+USB, PCIEx1 [Default]	If the device is PCIEx2, please select PCIEx1, otherwise select PCIEx1+USB

PCI Express Configuration

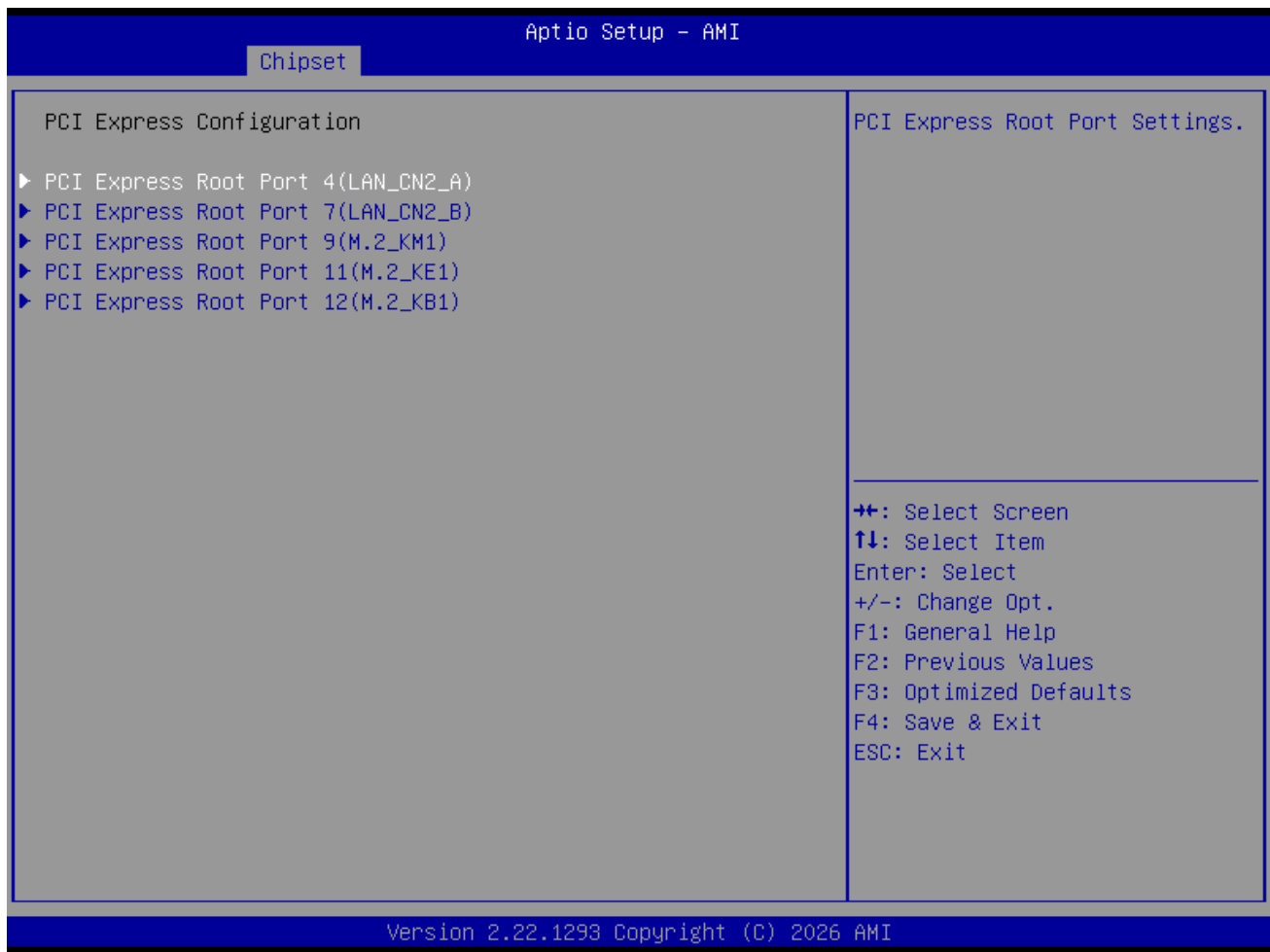

● PCI Express Root Port 4/7/9/11/12



Item	Options	Description
PCI Express Root Port 4/7/9/11/12	Disabled, Enabled [Default]	Control the PCI Express Root Port.
ASPM	Disabled [Default] , L1, Auto	Set the ASPM Level: Force L0s - Force all links to L0s State, AUTO - BIOS auto configure, DISABLE - Disables ASPM,
PCIe Speed	Auto [Default] , Gen1, Gen2, Gen3	Configure PCIe speed.

3.5 Security

Security menu allow users to change administrator password and user password settings.

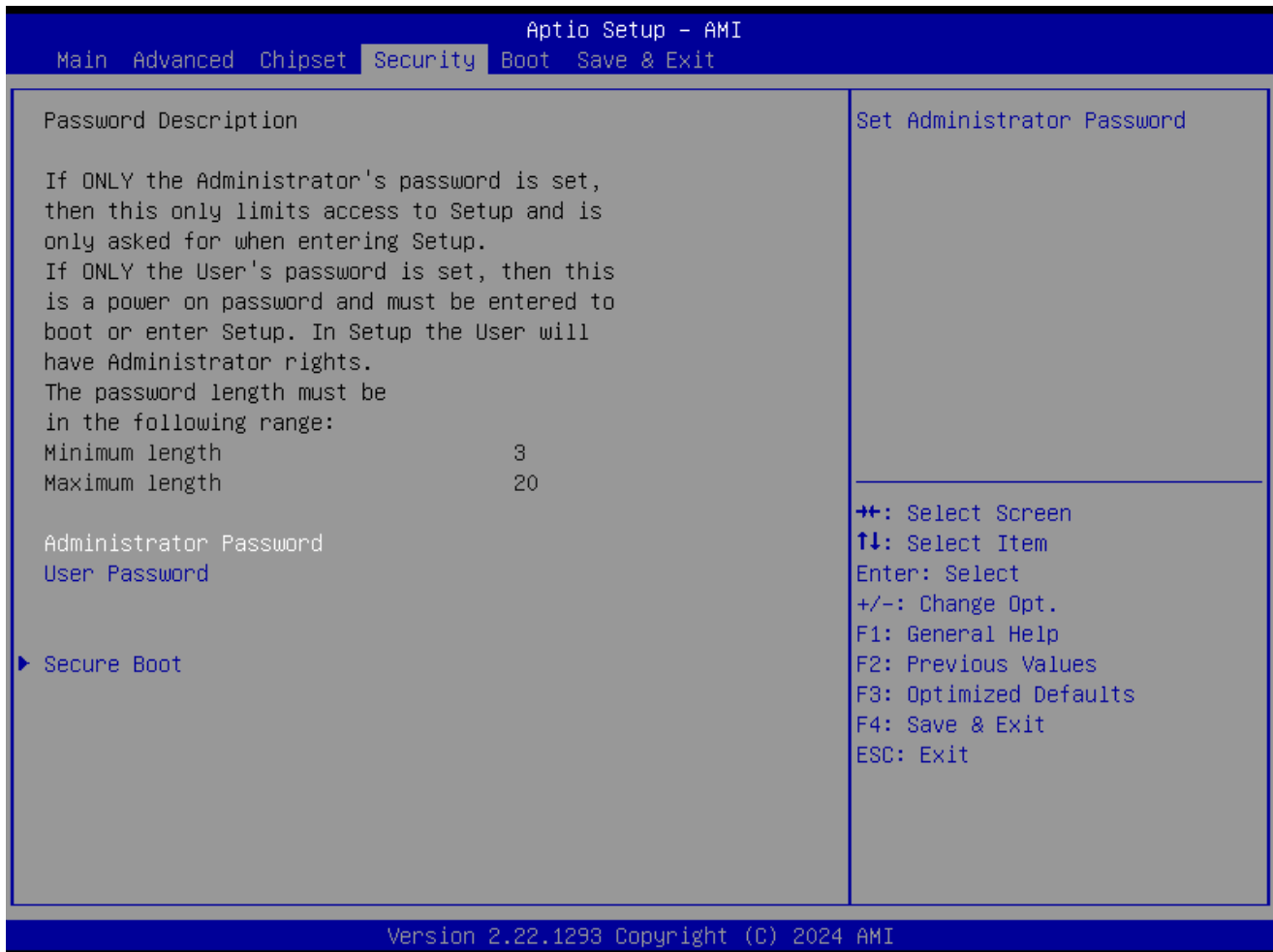

■ Administrator Password

This item allows you to set Administrator Password.

■ User Password

This item allows you to set User Password.

■ HD Audio Configuration

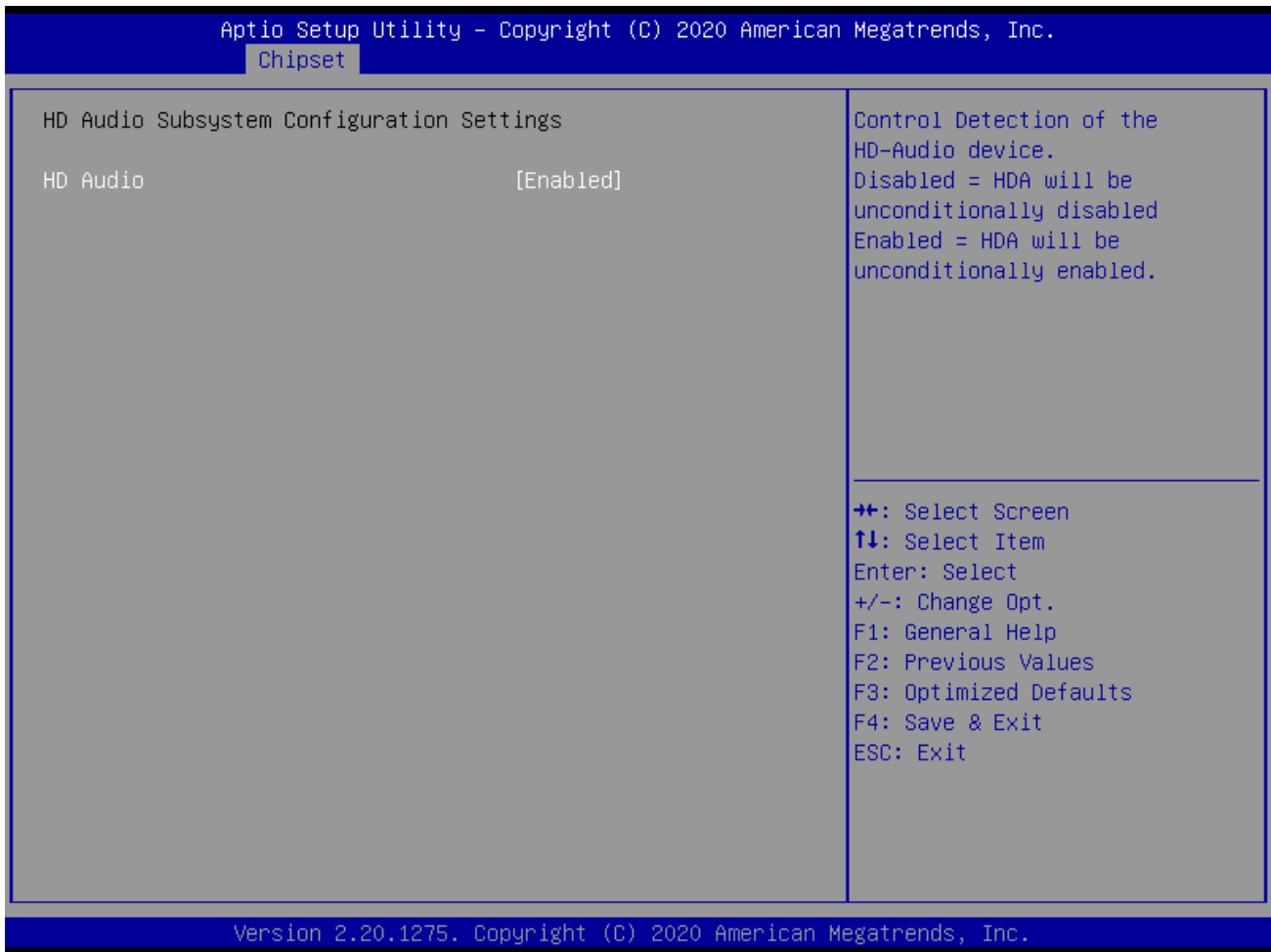

Item	Options	Description
HD Audio	Disabled, Enabled [Default]	Control Detection of the HD-Audio device. Disabled = HDA will be unconditionally disabled Enabled = HDA will be unconditionally enabled.

■ SATA Configuration



Item	Options	Description
SATA Controller(s)	Enabled[Default] Disabled	Enable/Disable SATA Device.
SATA Port	Disabled, Enabled[Default]	Enable/Disable SATA Port.

■ Security Boot

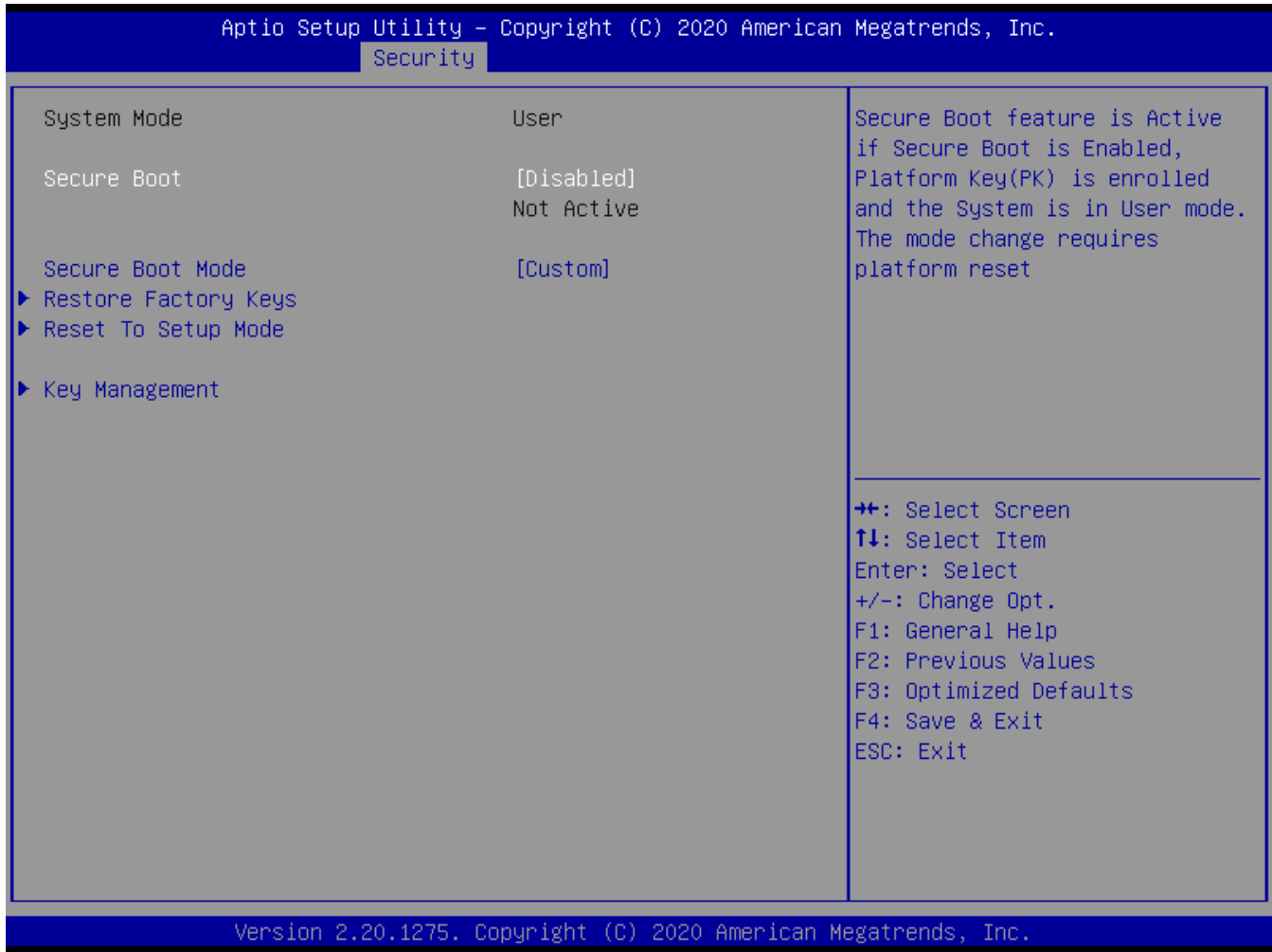

Item	Options	Description
Secure Boot	Disabled [Default] , Enabled	Secure Boot feature is Active if Secure Boot is Enabled, Platform Key(PK) is enrolled and the System is in User mode. The mode change requires platform reset
Secure Boot Mode	Standard, Custom [Default]	Secure Boot mode options: Standard or Custom. In Custom mode, Secure Boot Policy variables can be configured by a physically present user without full authentication

Item	Description
Restore Factory Keys	Force system to User Mode. Install factory default Secure Boot key databases
Key Management	Enables expert users to modify Secure Boot Policy variables without variable authentication

3.6 Boot

This menu allows you to setup the system boot options.

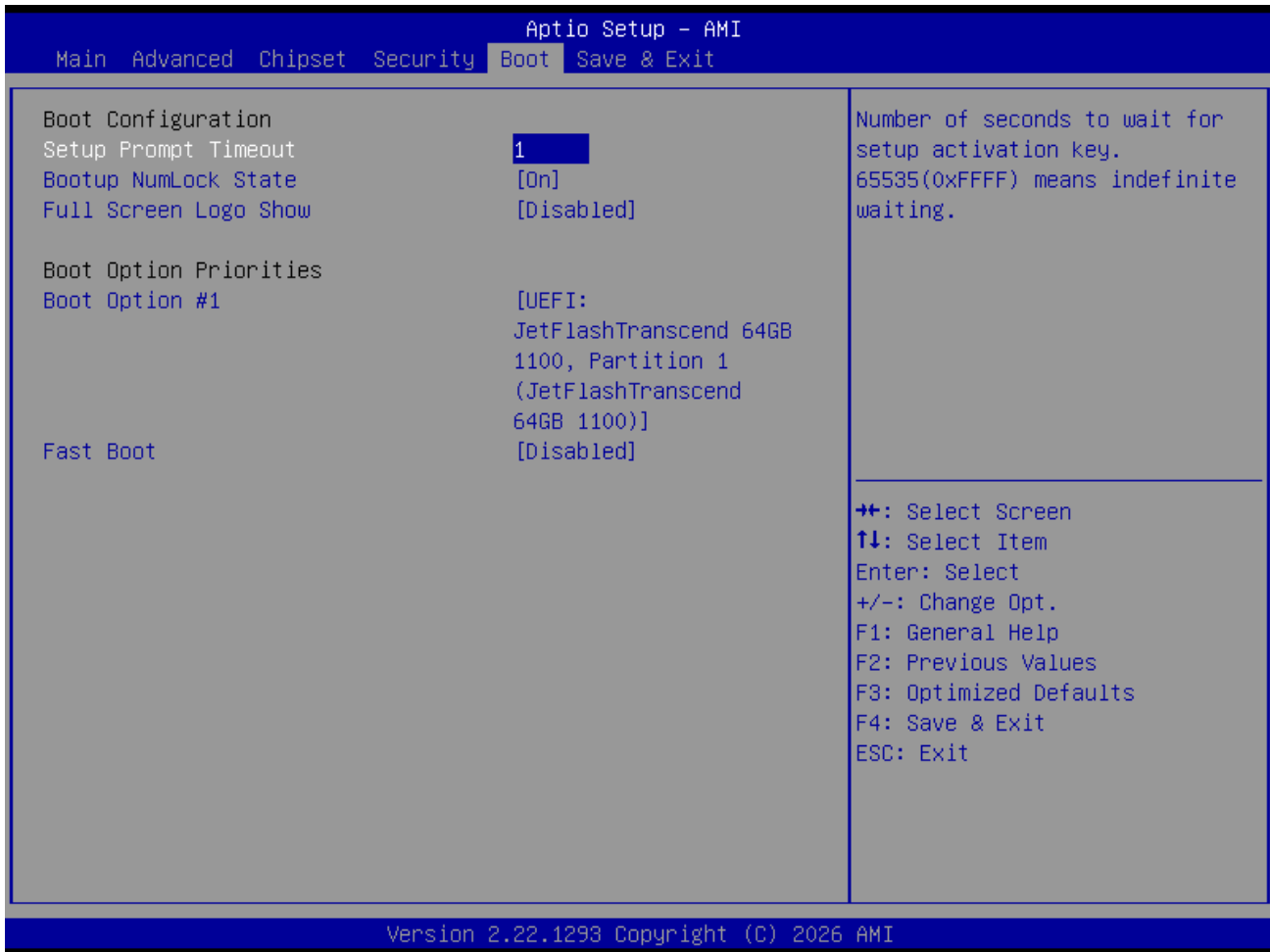

Item	Options	Description
Setup Prompt Timeout	1[Default]	Number of seconds to wait for setup activation key. 65535(0xFFFF) means indefinite waiting.
Bootup NumLock State	On[Default] , Off	Select the Keyboard NumLock state.
Full Screen Logo Show	Disabled[Default] , Enabled	Enables or disables Full Screen Logo Show option.
Fast Boot	Disabled[Default] , Enabled	Enables or disables boot with initialization of a minimal set of devices required to launch active boot option. Has no effect for BBS boot options.
Boot Option #1		Set the system boot order.

3.7 Save & Exit

This setting allows users to configure the boot settings.

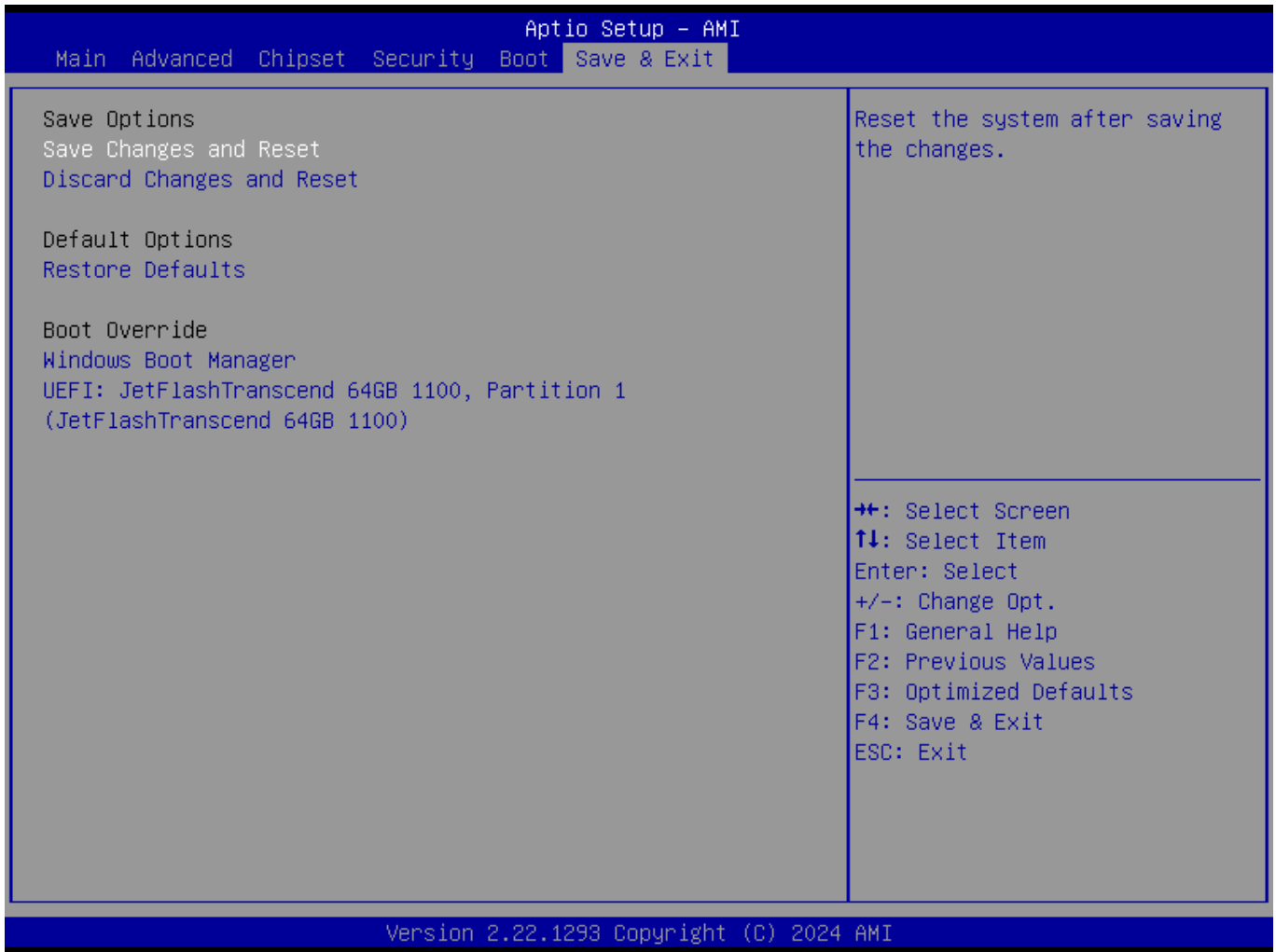

■ Save Changes and Reset

This item allows user to reset the system after saving the changes. This item allows user to reset the system after saving the changes.

■ Discard Changes and Reset

This item allows user to reset the system without saving any changes.

■ Restore Defaults

Use this item to restore /load default values for all the setup options.

Appendix

WDT & GPIO

This appendix provides the sample codes of WDT (Watch Dog Timer) and GPIO (General Purpose Input/Output).

WDT Sample Code

WDT Setting

Psuedo Code

// IO Address 0xA16 is time value(second)

// IO Address 0xA15 is WDT enable and configuration

Example, Set 0xA16=-0x02, 0xA15=0x31, it will reset after 2 seconds

```
#define TimePort      0xA16
#define TimeEnablePort 0xA15
```

//Set WDT Time Unit

```
buf1 = ReadByte(TimeEnablePort) & 0xf7; //Clear WDT mode.
```

```
// buf1 |= 0x08; //Bit3 :(1:Minute Mode/0:Second Mode)
```

```
WriteByte(TimeEnablePort, buf1);
```

//Set WDT Time Value

```
WriteByte (TimePort , 0x02); // Set 2 seconds
```

//Enable WDT

```
buf1 = ReadByte(TimeEnablePort);
```

```
buf1 |= 0x31;
```

//Bit5 :WD_EN,If this bit is set to 1, the counting of watchdog time is enabled.

//Bit4 :WD_PULSE ,Select output mode (0: level, 1: pulse) of WDTRST# by setting this bit.

//Bit1~0: Select output pulse width of WDTRST#. 0: 1 ms, 1: 25 ms, 2: 125 ms, 3: 5 sec.

```
WriteByte(TimeEnablePort, buf1);
```

// Disable WDT

```
buf1 = ReadByte(TimeEnablePort); // Read current WDT setting
```

```
buf1 = buf1 & 0xDF; // Disable WDT by set WD_EN (bit 5) to 0.
```

```
WriteByte(TimeEnablePort, buf1); // Write back WDT setting.
```

GPIO Sample Code

GPIO Setting

IO_DO4	I/O 0xA02h Bit3
IO_DO3	I/O 0xA02h Bit2
IO_DO2	I/O 0xA02h Bit1
IO_DO1	I/O 0xA02h Bit0
IO_DI4	I/O 0xA03h Bit3
IO_DI3	I/O 0xA03h Bit2
IO_DI2	I/O 0xA03h Bit1
IO_DI1	I/O 0xA03h Bit0

The GPIO function is provided by SIO, and it can be accessed through its GPIO port. To access the GPIO register, write value to data port. The configuration on the CT-DAS01 is described as below.

Psuedo Code

```
#define GPI_ADDR 0xA03h
#define GPO_ADDR 0xA02h
```

```
// 0xA03h is Pin Status(default 0x5F )(at IO_DI1(Bit0) ~ IO_DI4(Bit3))
ByteData = ReadByte (GPI_ADDR) //Read current Pin Status
```

```
//Offset 0xA02h default setting is 0x5F (output pin set to output high) (at IO_DO1(Bit0) ~ IO_DO4(Bit3))
ByteData = 0x0F //set IO_DO1~ IO_DO4 to high
WriteByte (GPO_ADDR, ByteData)
```

